

Life Safety Dampers - International

- Fire
- Smoke
- Combination Fire Smoke
- Ceiling Radiation



 **GREENHECK**
Building Value in Air.

June
2018



Greenheck's employees are deeply committed to being easy to do business with anywhere in the world. As an industry-leading manufacturer, our focus is to **build value in air**... by offering the widest range of reliable air movement and control products and to exceed your expectations for on-time delivery, easy installation, performance and operating efficiency.

Our commitment to our customers is what drives our long-standing sustainability practices. We continuously strive to reduce energy usage and other production costs to ensure competitive prices for you and ongoing business success. We support the health, safety and training of our employees to achieve the high quality product performance you expect from Greenheck — and deserve. And we take on the industry's most complex challenges by introducing innovative new product solutions to meet your future needs.

Our Mission: To be the market leader in the development, manufacture and worldwide sale of quality air moving and control equipment with total commitment to the customer.



Our Vision: Greenheck will be a company that exceeds customer expectations and that others strive to emulate. We will be the worldwide leader in providing timely, flexible and cost-effective solutions focused on the movement, cleaning, tempering, and control of air.

Building value in air — from the beginning.

Today, we're the world's largest manufacturer of commercial, institutional and industrial air movement and control equipment.

Greenheck's worldwide leadership in providing cost-effective, value-added solutions for air movement and control challenges evolved from rather humble beginnings. Bernie and Bob Greenheck weren't sure what lay ahead when they opened their small sheet metal shop in Schofield, Wisconsin USA in 1947. But they were determined that no product would ever leave their shop, unless it met the most stringent quality standards—their own. At first, the company manufactured a variety of sheet metal products. In 1956, Greenheck engineers developed a highly efficient power roof ventilator. This product and the innovative ventilation solutions that followed ultimately enabled us to expand our distribution throughout the world. Today, quality Greenheck products are efficiently moving air in commercial buildings, institutions and factories throughout North America, Latin America, the Middle East, and Asia.



The first factory.
1947



Bernie and Bob Greenheck
1956

Customer driven employees.

Greenheck employees continue to share an extraordinary commitment to meeting and exceeding customers' expectations. We know our future success depends on the value we bring to the market: reliable, top-quality products and exceptional service.



Table of Contents

| | |
|---|--------------|
| Introduction | 5-19 |
| Fire Dampers | 7-21 |
| Application | 7 |
| UL Standards | 8 |
| Installation Requirements | 9-11 |
| Special Installations | 12 |
| Difference Between Curtain and Multi-Blade Fire Dampers | 13-14 |
| Accessories | 15 |
| Selection and Sizing Charts | 16-21 |
| Smoke Dampers | 22-30 |
| Application | 22 |
| UL Standards | 23 |
| Installation Requirements | 24 |
| Construction | 25-26 |
| Actuators | 27-28 |
| Selection and Sizing Charts | 29-30 |
| Combination Fire Smoke Dampers | 31-39 |
| Application | 31 |
| Installation Requirements | 32-33 |
| Construction | 34-35 |
| Actuators | 36 |
| Closure Devices | 37 |
| Selection and Sizing Charts | 38-39 |
| Round Dampers | 40-41 |
| Ceiling Radiation Dampers | 42-44 |
| Application | 42 |
| Non-Combustible Assemblies | 42 |
| Combustible Assemblies | 43 |
| Options and Selection Chart | 44 |
| Performance (Pressure Drop) | 45-49 |
| Accessories | 50-55 |
| Factory Mounted Accessories | 50 |
| Testing Devices | 51 |
| Blade Indicators and Smoke Detectors | 52 |
| Transitions and installation | 53 |
| Convenience Features | 54 |
| Cost Saving Products | 55 |
| General Information | 56-63 |
| Model Definition | 56 |
| Drive Arrangement Definition | 57 |
| Specification Checklist | 58 |
| Modifications to Life Safety Dampers | 59 |
| Most Commonly Asked Questions | 60 |
| Inspection, Maintenance and Testing | 61 |
| Models by Manufacturing Location | 62 |

Life Safety Dampers

Life safety dampers are intended to protect openings in walls, ceilings, floors and/or partitions to prevent the spread of fire and/or smoke. The four types are:

- Fire Dampers
- Smoke Dampers
- Combination Fire Smoke Dampers
- Ceiling Radiation Dampers



Fire Dampers are required by building codes to maintain the required fire resistance ratings of walls, partitions and floors when they are penetrated by air ducts and transfer openings. These products are tested and classified in accordance with UL Standard 555.

Smoke Dampers have two applications:

1. They may be applied in a passive smoke control system where they simply close and prevent the circulation of air and smoke through a duct or a ventilation opening in a smoke barrier.
2. They may be applied as part of an engineered smoke control system designed to control the spread of smoke using the building's HVAC system and/or dedicated fans to create pressure differences.

These products are tested and classified in accordance with UL Standard 555S.

Combination Fire Smoke Dampers perform the function of both a fire damper and a smoke damper. These products are tested and classified in accordance with both UL 555 and UL 555S.

Ceiling Radiation Dampers are designed to protect penetrations through the ceiling membrane of fire resistive floor ceiling and/or roof ceiling assemblies. These products are tested and listed in accordance with UL Standard 555C and 263.

Codes and Standards

The terms “code” and “standard” are often used interchangeably but there is a fine point of difference. A code is a set of regulations and requirements written in appropriate language with the expectation that it will become law. A code is enacted into law when it is adopted by formal action of a governing body or other authority having jurisdiction.

A standard is not necessarily written with the expectation that it will be adopted by some authority having jurisdiction and become law. Rather, a standard is intended to establish a defined level of performance or requirements, and often includes a listing of the necessary tests and qualifications for compliance with the standard. Codes often reference standards making them a part of the referencing code. For example, the 2018 International Building Code references UL (Underwriters Laboratory Standard 555 as the appropriate standard for qualifying fire dampers for use under the International Building Code.



Compliance with the Applicable Building Codes is Mandatory

If a state, city, or other authority having jurisdiction has adopted one or more codes governing construction within that jurisdiction, these codes are the law and must be followed. As there are many code documents in existence that have not been adopted by every authority with jurisdiction, it is important that both the designer and contractor know exactly what codes are applicable to the building in question.



The intent of the International Building Code is to provide minimum requirements to safeguard the public health, safety, and general welfare of the occupants of new and existing buildings and structures (2018 IBC, page ix).

The subject of codes and standards cannot be treated in any depth in the space available in this manual. See installation instructions and installation supplements for specific information.

The National Fire Protection Association

The National Fire Protection Association merits special mention because of its significance as a standard writing and trend setting organization in the fire and life safety arena. NFPA, a non-profit membership organization founded in 1896, brings together all interested parties to promote safety from fire, electricity, and related hazards through research, codes and standards, technical services, and public education. Many of NFPA's Codes and Standards provide the basis for model building code requirements or actually become a part of these codes. New concepts and other changes in various NFPA Standards are usually adopted by the several model building codes during the code review and revision process. The codes that affect fire dampers, combination fire smoke dampers, and smoke dampers are NFPA 80, 90A, 90B, 92, 101, and 105.



California State Fire Marshal (CSFM)

The office of State Fire Marshal requires products to go through an approval, testing, and listing process for California. The CSFM listing service provides building authorities, architectural and engineering communities, contractors, and the fire service with a reliable and readily available source of information.



FM Global

FM Global manages a non-profit research and testing organization which tests and provides approvals for building products to help minimize losses in buildings they insure. FM approved products meet rigorous property loss prevention testing and certification standards. This approval gives the building owner an edge on receiving and maintaining advantageous financing and insurance rates.

AMCA

The AMCA Certified Rating Program seal assures you that a product line has been tested to the appropriate AMCA standards in accordance with a legal license agreement and that the manufacturer's cataloged certified ratings have been submitted to AMCA for approval.



Application

Fire dampers are required by building codes to maintain the required fire resistance ratings of walls, partitions, barriers, and floors when they are penetrated by air ducts or other air transfer openings.

One of the basic requirements of building fire protection is the compartmentation, or dividing up of buildings using fire rated walls and floors. This compartmentation concept is intended to contain any fire to the compartment of origin and thereby minimize damage to property and protect the lives of people living and/or working in the building. A duct or ventilation opening in any of the fire rated partitions could permit a fire to spread from the compartment of origin to adjoining compartments. Fire dampers are installed in these duct or ventilation openings. They close automatically upon detection of heat by a heat-responsive device (usually by the melting of a fusible link), blocking the opening and preventing the spread of fire into the adjoining compartment.



Hourly Fire Rating

Walls, floors, or partitions with a fire resistance rating of 3 hours or more require fire dampers with a 3 hour rating. Fire resistance ratings less than 3 hours require an 1½ hour rated fire dampers.

| Type of Penetration | Minimum Damper Rating |
|--|-----------------------|
| Less than 3 hour fire resistance rated assemblies | 1½ hours |
| 3 hour or greater fire resistance rated assemblies | 3 hours |

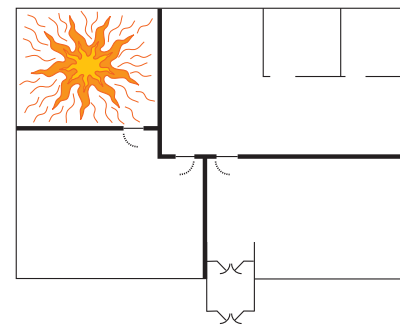

Fire rated partitions contain fire damage to the compartment of fire origin.

Static vs. Dynamic

Fire dampers carry a UL 555 rating and can be either STATIC or DYNAMIC rated.

Static rated fire dampers have no airflow closure rating and can only be applied in HVAC systems that are designed to shut down automatically in the event of a fire.

Dynamic rated fire dampers carry a UL 555 rating to close while the HVAC system is running. Dynamic rated fire dampers carry both an airflow velocity (ft/min) rating and a pressure differential rating (in. wg) and should be selected to operate against the conditions they will see in their application. Dynamic rated fire dampers are always an appropriate selection for either HVAC system.

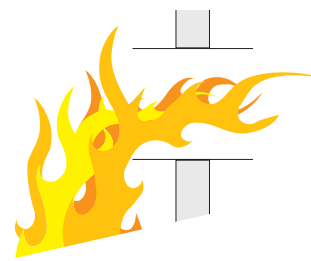

Unprotected partition

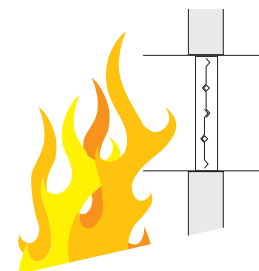

Partition protected by fire damper

UL Standards for Testing and Rating of Fire Dampers

UL (Underwriters Laboratories) Classified fire dampers are tested to UL Standard 555 “Fire Dampers”. They are always supplied with an appropriate UL label. Below are some of the test requirements that UL 555 classified dampers are subjected to.



Fire Endurance Test and Hose Stream Test (UL 555)

Dampers are exposed to a standard fire test for a period of either 1½ or 3 hours. This standard fire test is controlled to follow the time temperature curve illustrated. Immediately after the conclusion of the fire test, the dampers are subjected to a high pressure hose stream test. During the test a water pressure of 30 psi (207 kPa) for 1½ hour dampers and 45 psi (310 kPa) for 3 hour dampers is applied at a distance of 20 feet (6 meters). The hose stream test provides an extreme shock that ensures the dampers are structurally strong enough to withstand the rigors of the most severe fire conditions.

Dynamic Closure Test (UL 555)

The UL 555 dynamic closure test evaluates the ability of a fire damper or combination fire smoke damper to close under airflow. The minimum velocity at which a dynamic closure rating can be issued is 2000 fpm. Extended ratings can be achieved in increments of 1000 fpm. As a safety factor to achieve a given rating, the damper is tested at 400 fpm above the desired rating. The damper is tested three times at ambient air conditions and then a fourth time with the air heated such that the damper’s temperature response device causes the damper to close.

Salt Spray Exposure Test (UL 555 & UL 555S)

A damper sample is exposed to salt spray in a test chamber for a period of 120 hours. After this exposure, the damper must close (and latch if a latch is provided). This test demonstrates a damper’s ability to function after a more severe fouling than the damper is likely to experience during its intended application.

UL 555 requires closure devices to have a minimum temperature rating of 160°F (71°C). The maximum temperature rating is 212°F (100°C) for static rated dampers and 350°F (177°C) for dynamic rated dampers. In addition, the IBC states “The operating temperature shall be approximately 50°F (10°C) above the normal temperature within the duct system”.

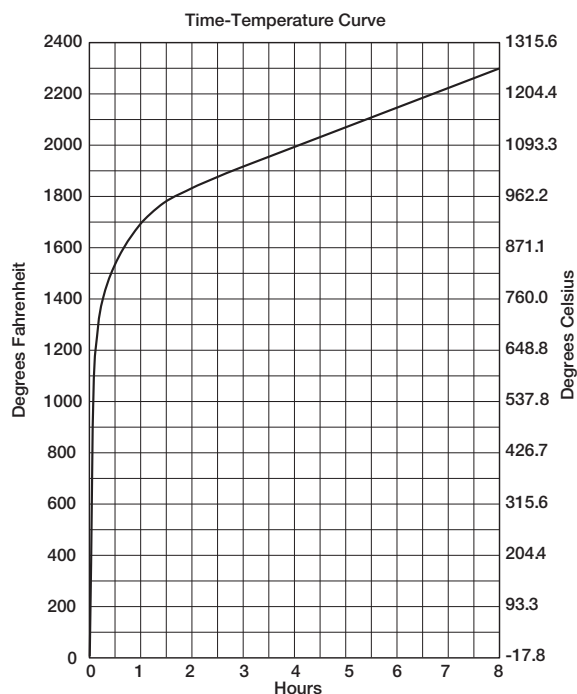

Cycling Test (UL 555)

A non-actuated damper (gravity or spring force) must be cycled open and closed 250 times. An actuated damper must be cycled 20,000 times. A damper with an actuator that has previously been subjected to the Operational Reliability Cycle Test is exposed to an elevated temperature of 250°F (121°C) minimum (or higher in multiples of 100°F [38°C]) for a period of 30 minutes. After 30 minutes of exposure and while still at the elevated temperature, the damper actuator must operate the damper open and closed three times. Time of operation cannot exceed 75 seconds for any of the open or closed operations.

The IBC (International Building Code) requires life safety dampers to be installed in accordance with the manufacturer's installation instructions and the damper's listing.

UL requires all fire, smoke, and combination fire smoke damper manufacturers to publish specific damper installation instructions detailing the required installation methods and procedures to properly install each specific model of damper. These instructions must be followed to maintain the validity of the damper's UL listing. A copy of the appropriate installation instruction(s) is included with each shipment of UL fire, smoke, or combination fire smoke dampers. Installation requirements may differ between damper manufacturers as a manufacturer may qualify alternate installation methods by conducting additional tests. Dampers must be installed in accordance with instructions published by the company that manufactured the dampers.

Mounting Orientation

Fire dampers are required to pass separate tests for vertical mount and horizontal mounting applications. Dampers need to be installed in the correct orientation to ensure life safety and proper fire protection. Every fire damper is supplied with a label identifying the required mounting orientation. **These mounting orientations are not interchangeable.**

Vertical mount dampers must be installed in masonry, block, or stud walls. Horizontal mount dampers must be installed in concrete floors except when using the I503 horizontal non-concrete application (see Special Installations).

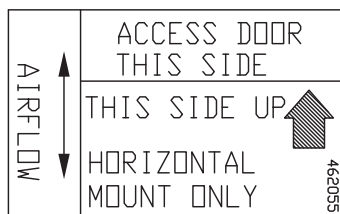

**Horizontal Label
(curtain style)**

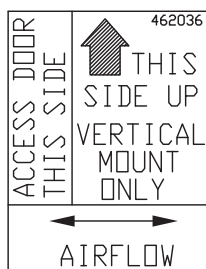

**Vertical Label
(curtain style)**

Clearances required between damper sleeves and wall or floor openings

Clearance requirements are different between two sided and single side angle installation. (See Installing damper/sleeve assembly in wall and floor openings, page 9, for limitations).

Two-sided angle installations require clearances of:

- For galvanized steel dampers: $\frac{1}{8}$ in. (3mm) per foot of damper width or height for galvanized steel dampers with a minimum of $\frac{1}{4}$ in. (6mm) and a maximum of 1½ inches (38mm).
- For stainless steel dampers: $\frac{3}{16}$ in. (5mm) per foot of damper width or height with a minimum of $\frac{1}{4}$ in. (6mm) and a maximum of 2 inches (51mm).
- On true round dampers, the wall/floor opening must be a minimum of $\frac{7}{8}$ in. (22mm) larger than the outside diameter of the damper.

Vertical mount single side angle installation has no minimum clearance requirements. However, we recommend clearances between the wall opening and the sleeve to make installation easier. A horizontal mount installation requires clearances of $\frac{1}{8}$ in. (3mm) per foot of damper width and height with a minimum clearance of $\frac{1}{4}$ in. (6mm).

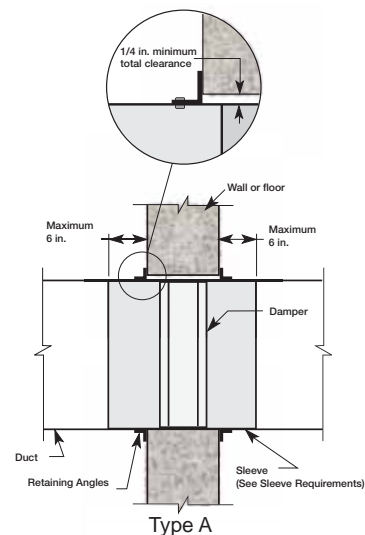

Installation

Sleeve Requirements

All UL fire and combination fire smoke damper listings require that the damper be mounted in a sleeve of a required gauge and length prior to installation. A factory supplied sleeve ensures the correct gauge is used and the damper will be ready to install. If the sleeve is installed in the field, the installation instructions show you the method of attaching the sleeve and damper together. The sleeved damper is installed in the wall or floor opening and retained as part of the structure by angles attached to the sleeve. UL requires that connecting ducts terminate at each end of the damper sleeve.

Sleeve gauge requirements depend on the damper size and type of duct-to-sleeve connection used. Table 1 provides minimum fire and combination fire smoke damper sleeve thickness requirements as defined by UL 555.

Sleeves shall extend a maximum of 6 in. (152mm) beyond the wall or floor opening on each side. When a factory mounted access door is provided, the sleeve may extend a maximum of 16 in. (406mm) beyond the wall or floor opening on the access door side.

| Sleeve Gauge | Duct Dimension | Type of Duct to Sleeve Connection Permitted |
|---|--|---|
| 14 ga. (0.075 in.) - 10 ga. (0.138 in.) [2mm - 3.5mm] | All duct sizes | Rigid or Breakaway |
| 16 ga. (0.060 in.) [1.5mm] | 36 in. (914mm) max. width 24 in. (610mm) max. height 24 in. (610mm) diameter | Rigid or Breakaway |
| 16 ga. (0.060 in.) [1.5mm] | All duct sizes | Breakaway only |
| 18 ga. (0.048 in.) [1.2mm] | 85 in. (2159mm) wide and over | |
| 20 ga. (0.036 in.) [0.9mm] | 55 in. - 84 in. wide (1397mm - 2134mm) | |
| 22 ga. (.030 in.) [0.76mm] | 31 in. - 54 in. wide (787mm - 1372mm) | |
| 24 ga. (0.024) [0.6mm] | 13 in. - 30 in. wide (330mm - 762mm) | |
| 26 ga. (0.018 in.) [0.46mm] | 12 in. wide and under (305mm) | |

Sleeve thickness must not be less than the gauge of the connecting duct. UL Standard 555 requires all ducts to terminate at fire damper sleeves.

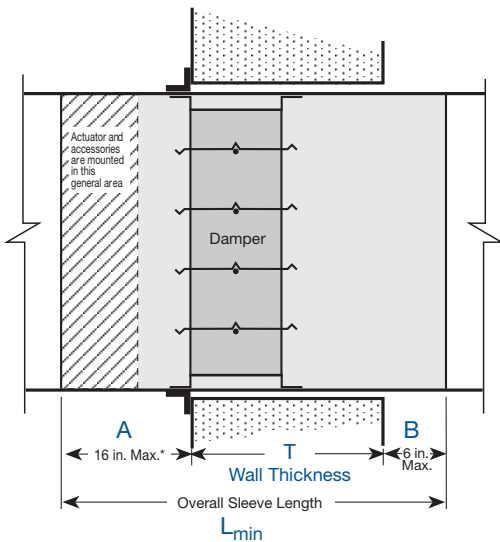

* actuator side or factory mounted access door

Sleeve Length Considerations

Greenheck's standard and most economical sleeve lengths are 16, 21, and 24 inches (406, 533, and 610mm)

| | | |
|-----------|---|--|
| L_{min} | = | $A + B + T$ |
| L_{min} | = | minimum sleeve length |
| A | = | length of sleeve beyond wall (actuator side or factory mounted access door) |
| B | = | length of sleeve beyond wall (on side without actuator or factory mounted access door) |
| T | = | wall thickness |

| Wall or Floor Thickness Inches (mm) | Sleeve Length Required Inches (mm) |
|-------------------------------------|------------------------------------|
| 4 - 6 (102 - 152) | 16 - 21 (406 - 533) |
| 7 - 10 (178 - 254) | 21 - 24 (533 - 610) |
| 11 - 13 (279 - 330) | 24 - 28 (610 - 711) |

Installing damper/sleeve assembly in wall and floor openings

With the exception of dampers that are specifically designed to be mounted outside the plane of the wall/floor opening (see special installation), the fire damper must be installed such that the centerline of the blades are mounted in the plane of the wall or floor. All fire dampers may utilize the two sided angle installation method. On 1½ hour rated fire dampers, you may use the single side angle installation method up to the following maximum sizes:

- Vertical mount: 80 in. W x 50 in. H, 50 in. W x 80 in. H or 40 in. W x 100 in. H (2032mm x 1270mm, 1270mm x 2032mm, or 1016mm x 2540mm)
- Horizontal mount: 144 in. W x 96 in. H (3658mm x 2438mm)

Duct-to-sleeve connections

Dampers requiring duct-to-sleeve connection, UL allows a rigid or breakaway connection.

A rigid connection is, by UL's definition, any connection that has not been qualified as a breakaway connection.

A number of qualified breakaway connections, as well as procedures for qualifying additional breakaway connections, are defined in UL Standard 555. All qualified breakaway connections must be described in the damper manufacturer's fire and combination fire smoke damper installation instructions.

Examples of qualified breakaway connections are:

- Transverse joints on the top and bottom
- Drive slip joints on the sides
- Type R or O damper transitions
- Manufactured flanged systems manufactured by Ductmate, Durodyne, Ward, Nexus, Radiant T-35m, and MEZ
- Proprietary flange system: TDC by Lockformer and TDF by Engle

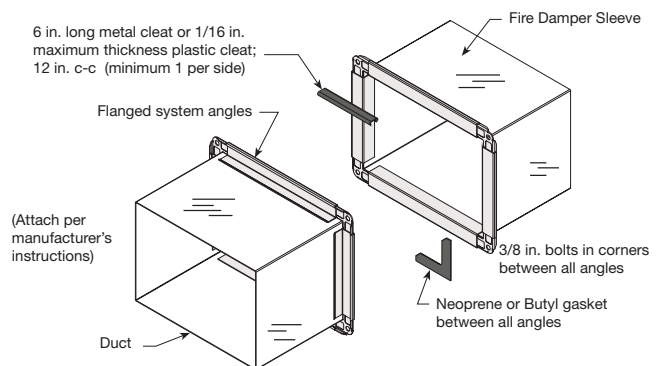
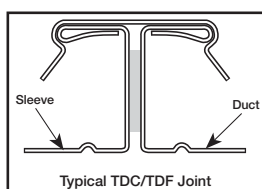
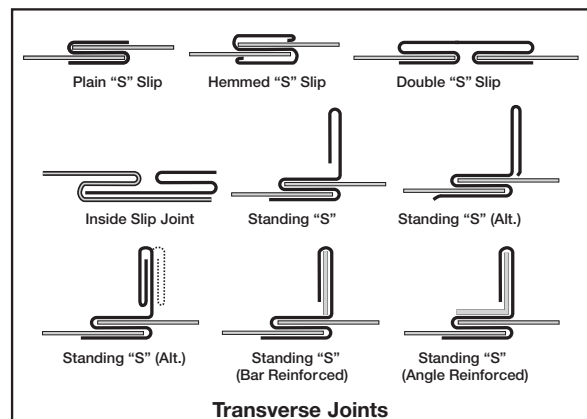
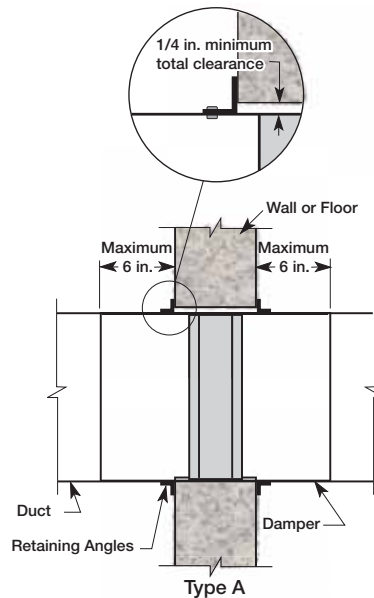

Manufactured Flanged Systems

Special Installation

What if a Damper Cannot be Installed in the Wall?

Greenheck has tested and qualified fire and combination fire smoke dampers for installation out of the plane of the wall (models OFD, ODFD, GFSD and OFSD). This damper series is primarily designed to allow ‘through the grille’ access to actuators and controls. Model OFSD and GFSD series dampers meet all requirements of UL 555 and UL 555S.

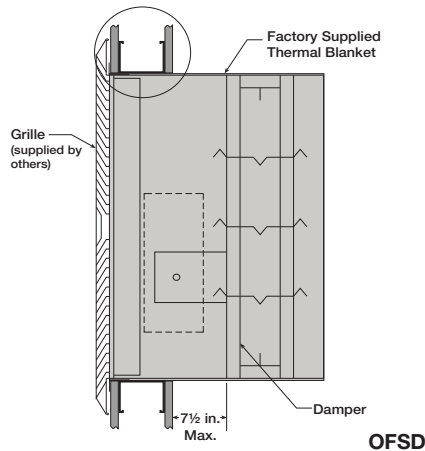

Single 3 Sided Retaining Angle

Greenheck has tested and qualified 3 sided retaining angle installation fire and combination fire smoke dampers mounted in masonry, block, metal or wood stud walls. A retaining angle is used on the top and sides of the damper. A retaining angle is not required on the bottom side of the damper. The damper shall rest directly on the wall opening.

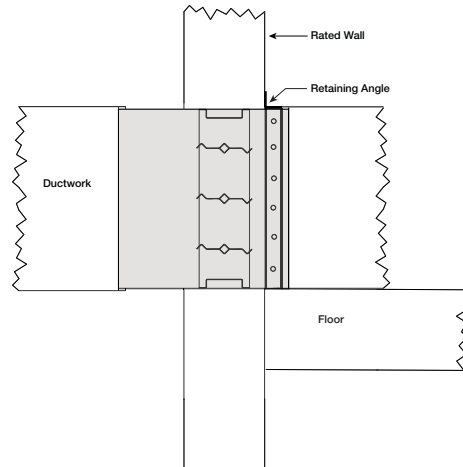

Horizontal Fire Smoke Damper in a Non-Concrete Barrier

Fire rated shafts enclose the space extending through one or more stories of a building, connecting vertical openings in successive floors, or floors and roof. One of the more difficult tasks facing designers, contractors, and inspectors when working with a shaft that is penetrated by a duct, is protecting the horizontal opening at the top or bottom of the rated shaft. There are three typical methods used to enclose the bottom of the shaft when it does not extend to the top or bottom of the building or structure.

Method 1: Using a fire resistant rated construction

It is important to note that when a shaft is enclosed at the bottom with fire resistant rated construction, it is required that the assembly has passed the fire test in the horizontal position and any penetrations in the shaft be protected per applicable building codes. Duct penetrations can then be protected with vertically mounted fire smoke dampers.

Method 2: Terminate the shaft in a room

The shaft and room need to be separate from the remainder of the building with construction equal to the fire resistive rating of the shaft. Duct penetrations can then be protected with vertically mounted fire smoke dampers.

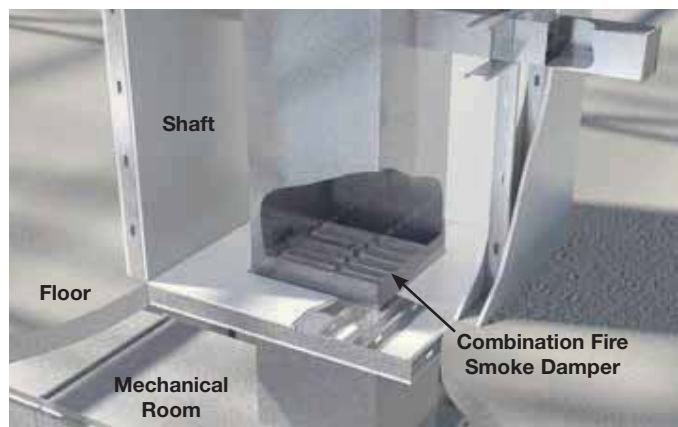

Method 3: Using a 2 hour fire rated floor/ceiling design (I503)

UL Fire Resistance Design Number I503 is the first UL listed floor/ceiling design made from steel studs and gypsum board that is approved with damper penetrations. Greenheck series DFD, FD and FSD dampers are approved to be used in this innovative design. This installation method results in more usable space for the owner, more flexibility for the design professional, and reduces installation time for the contractor.

Curtain Style Fire Dampers

Mounting

Fire dampers are available for mounting either vertically or horizontally (not interchangeable in the field). Greenheck also offers fire dampers for out-of-the-wall installation.

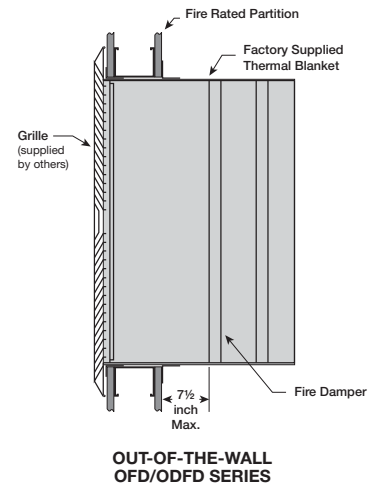
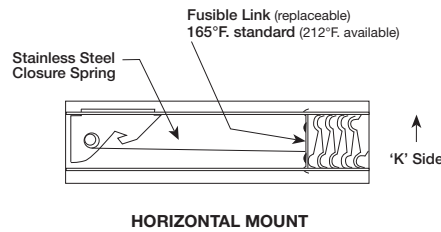
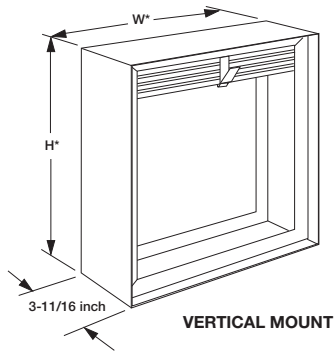

Close Indicator Switch

An optional accessory for curtain style fire dampers is the close indicator switch. The switch provides remote confirmation when the damper has closed.



Integral Sleeve (X series)

X series dampers in the FD and DFD model lines have the sleeve formed with the fire damper frame as one piece, providing the most economical solution for sleeved fire dampers. The frame with integral sleeve is constructed of galvanized steel.

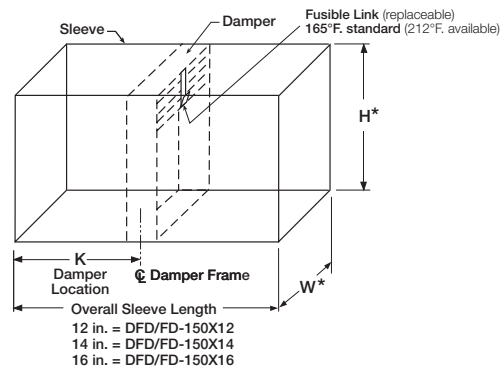

Multi-Blade Fire Dampers

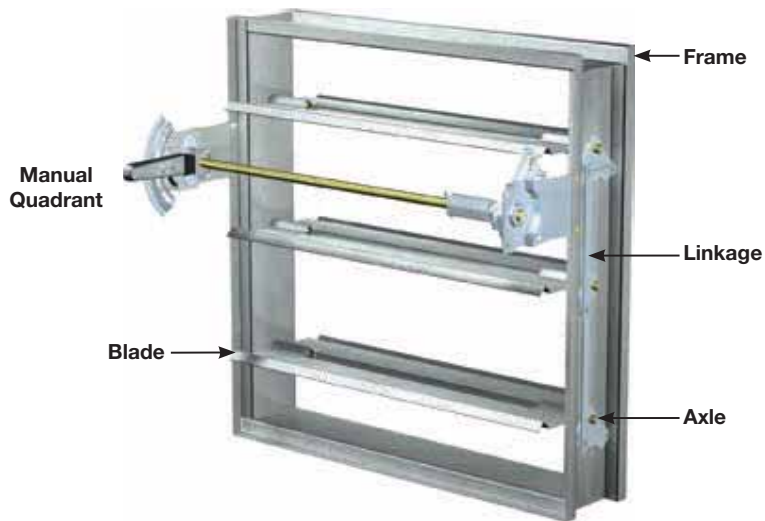

Mounting

Single section multi-blade fire dampers may be mounted vertically or horizontally as long as the blades stay horizontal. Multiple section multi-blade fire dampers must be mounted in the orientation in which they were ordered.

Frame - Tog-L-Loc® Advantage

Greenheck multi-blade fire dampers utilize a 5 in. x 1 in. (127mm x 25mm) hat channel frame. Each frame is built with four separate pieces of material and joined by our Tog-L-Loc® process. The Tog-L-Loc® process provides a more rigid frame that resists “racking” better than welded construction.



Tog-L-Loc® Reinforced Corner

Maximize Performance - Low Profile Frame

On dampers that are 17 in. (432mm) high or less, Greenheck uses a low profile top and bottom frame to maximize free area, allowing for lower pressure drop and improved damper performance.



Variable Symmetric Blade Design (VSB) - a Greenheck Exclusive!

- Blades are symmetric about their axis
- Combination of 4, 5, 6, and 7 in. (102, 127, 152, and 178mm) blade widths are used in a single damper
- Reduces the need for closure strips which optimize pressure drop performances
- Damper can be mounted in either direction of airflow
- Through extensive testing of our dampers, we have determined using various blade sizes reduces required actuator torque which reduces the size and quantity of actuators used on dampers. This reduces first costs for the building owner and on-going electrical power consumption.

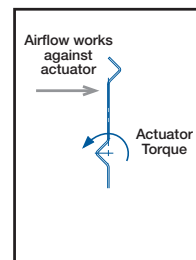

Unbalanced Blade
Requires Higher Torque

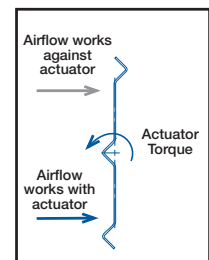

Balanced Blade
Requires Less Torque

Factory Sleeve Option

Fire dampers are available with factory-furnished sleeves. Sleeves are galvanized steel or stainless steel, depending on the model, and are available in gauges 10 through 20 (3 through 1 mm) thicknesses, and lengths up to 48 in. (1219mm).

Curtain Style Fire Dampers

The “K” dimension specifies the location of the damper within the sleeve. Horizontal dampers must be installed with the “K” dimension on the top (K-side facing up).

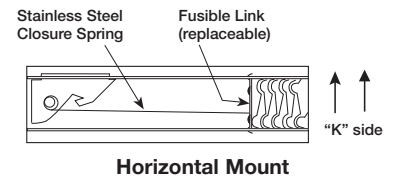

Multi-Blade Fire Dampers

The “A” dimension specifies the location of the damper within the sleeve.

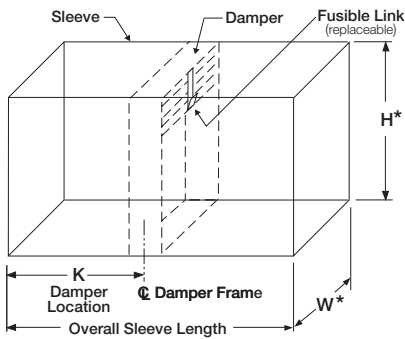

Curtain Fire Damper in a Sleeve

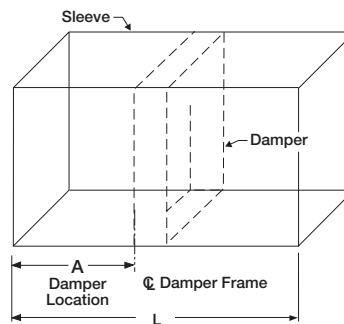

Multi-Blade Fire Damper in a Sleeve

Transitions

When a rectangular fire damper is being used in conjunction with round, square or oval ductwork, they can be supplied in a factory sleeve with round, square or oval transitions on one or both ends of the sleeve. Dampers should be ordered to the duct dimensions. For medium pressure ductwork, Greenheck can seal the transition and sleeve seams to prevent air leakage.

Transitions for Curtain Style Fire Dampers

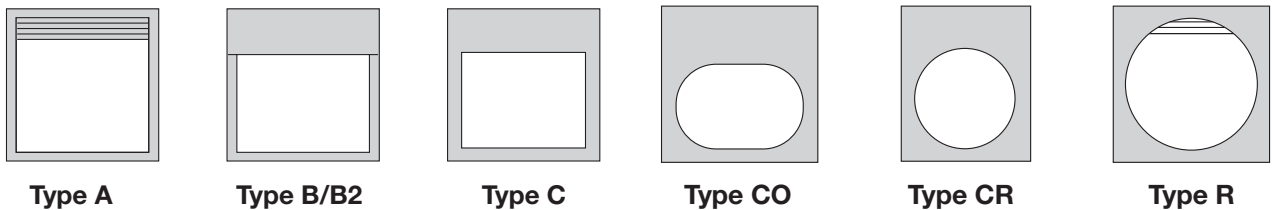

Transitions for Multi-Blade Style Fire Dampers

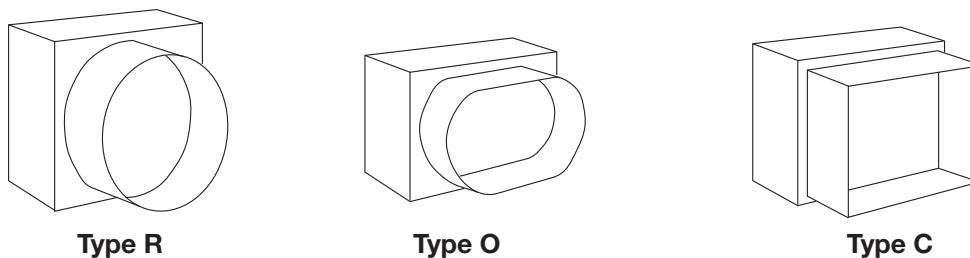

Quick Reference Guide

Fire Dampers

| X = Standard O = Optional | Construction | | | | | Material | | | Blade Profile | | | Fire Rating | | Closure Temperature | | | | Accessories |
|------------------------------|--------------------------------------|--|---|---------------------------------------|--|------------------|---------------------|---------------------|---------------|---------|----|-------------|--------|---------------------|---------------|---------------|---------------|------------------|
| | Ultrathin Frame 1 1/2 in. (38 mm) | Narrowline Frame 2 3/16 in. (56 mm) | Integral Sleeve 12, 14, 16 in. length (305, 356, 406 mm) | Standard Frame 3 11/16 in. (94 mm) | 5 in. x 1 in. 16 ga. (127 x 25 x 1.5 mm) Hat Channel Frame | Galvanized Steel | 304 Stainless Steel | 316 Stainless Steel | Curtain | Airfoil | 3V | 1 1/2 Hour | 3 Hour | 165°F (74°C) | 212°F (100°C) | 286°F (141°C) | 350°F (177°C) | Retaining Angles |
| DFD-110 | | X | | | | X | | | X | | | X | | X | O | O | | O |
| DFD-150 | | | | X | | X | | | X | | | X | | X | O | O | | O |
| SSDFD-150 | | | | X | | | X | | X | | | X | | X | O | | | O |
| DFD-150X series | | | X | | | X | | | X | | | X | | X | O | O | | O |
| ODFD-150 | | | | X | | X | | | X | | | X | | X | O | O | | O |
| DFD-210 | | | | | X | X | | | | | X | X | | X | O | O | O | O |
| DFDAF-310 | | | | | X | X | | | X | | | X | | X | O | O | O | O |
| DFDAF-330 | | | | | X | X | | | X | | | X | | X | O | O | O | O |
| SEDFD-210 | | | | | X | | X | | | X | X | | X | X | O | O | O | O |
| SSDFD-210 | | | | | X | | X | | | X | X | | X | X | O | O | O | O |
| DFD-310 | | X | | | | X | | | X | | | X | X | X | O | O | | O |
| DFD-350 | | | | X | | X | | | X | | | X | X | X | O | O | | O |
| SSDFD-350 | | | | X | | | X | | X | | | X | X | X | O | | | O |
| FD-100 | X | | | | | X | | | X | | | X | | X | O | O | | O |
| FD-110 | | X | | | | X | | | X | | | X | | X | O | O | | O |
| FD-150 | | | | X | | X | | | X | | | X | | X | O | O | | O |
| SSFD-150 | | | | X | | | X | | X | | | X | | X | O | O | | O |
| FD-150X series | | | X | | | X | | | X | | | X | | X | O | O | | O |
| OFD-150 | | | | X | | X | | | X | | | X | | X | O | O | | O |
| FD-300 | X | | | | | X | | | X | | | X | X | X | O | O | | O |
| FD-310 | | X | | | | X | | | X | | | X | X | X | O | O | | O |
| FD-350 | | | | X | | X | | | X | | | X | X | X | O | O | | O |
| SSFD-350 | | | | X | | | X | | X | | | X | X | X | O | O | | O |



DFD/FD



DFD/FD X Series



DFDAF-310/330



DFD-210

Maximum Damper Size Limitations

The maximum size opening that can be protected by any manufacturer's fire damper is specifically stated in the manufacturer's UL Listing. These listings, which can be found on UL's website (www.ul.com) under the category EMME, provide both the maximum single section size and the maximum multiple section size of a damper model. If no multiple section size is listed, the damper is limited strictly to single section applications.

The maximum damper sizes found in the UL Listings are based on tests conducted in accordance with UL Standard 555 (fire dampers). Filling openings larger than the maximum tested damper size is not approved by UL unless the opening requires only a static rated fire damper. Oversized openings in dynamic systems cannot be divided into smaller sections using support mullions. As always, the authority having jurisdiction can decide whether or not to approve an installation.

Static Fire Dampers – Models and Sizes

| Model | Mounting Horizontal or Vertical (H or V) | Maximum Single Section Size W x H, in inches (mm) | | | | | | | Maximum Multi section W x H, in inches (mm)* | | | | |
|------------|---|---|--------------------------|--------------------------|--------------------------|-----------------|-----------------|-----------------|--|--|---|---|--------------|
| | | No Transitions or A style | B/B2 | C & CO | CR | R | | | A | B/B2 | C & CO | CR | |
| | | | | | | 0 in. offset | 1 in. offset | 2 in. offset | | | | | |
| 1 1/2 Hour | FD-100 | V | 48 x 48 (1219 x 1219) | 48 x 40 (1219 x 1016) | --- | --- | --- | | | --- | | | |
| | FD-110 | H or V | 48 x 48 (1219 x 1219) | 48 x 42 (1219 x 1067) | --- | --- | --- | | | 96 x 48 (2438 x 1219) | 96 x 42 (2438 x 1067) | ---- | ---- |
| | FD-150 | H or V | 48 x 48 (1219 x 1219) | 48 x 42 (1219 x 1067) | 46 x 41 (1168 x 1041) | 41 (1041) | 30 (762) | 47 (1194) | 46 (1168) | 96 x 48 or 120 x 40 (2438 x 1219 or 3048 x 1016) | 96 x 42 or 120 x 35 (2438 x 1067 or 3048 x 889) | 94 x 41 or 118 x 34 (2438 x 1041 or 2997 x 864) | 41 (1041) |
| | | V | 37 x 37 (940 x 940) | 37 x 32 (940 x 813) | 37 x 31 (940 x 787) | 31 (787) | 30 (762) | 36 (914) | 35 (889) | 74 x 74 (1880 x 1880) | 74 x 69 (1880 x 1753) | 72 x 68 (1829 x 1727) | 68 (1727) |
| | FD-150X12 FD-150X14 FD-150X16 | H or V | 48 x 48 (1219 x 1219) | 48 x 42 (1219 x 1067) | 46 x 41 (1168 x 1041) | 41 (1041) | 30 (762) | 47 (1194) | 46 (1168) | --- | | | |
| | SSFD-150 | V | 48 x 48 (1219 x 1219) | 48 x 42 (1219 x 1067) | 46 x 41 (1168 x 1041) | 41 (1041) | 30 (762) | 47 (1194) | 46 (1168) | 96 x 48 or 120 x 40 (2438 x 1219 or 3048 x 1016) | 96 x 42 or 120 x 35 (2438 x 1067 or 3048 x 889) | 94 x 41 or 118 x 34 (2438 x 1041 or 2997 x 864) | --- |
| | | H | 36 x 36 (914 x 914) | 36 x 31 (914 x 787) | 34 x 30 (864 x 762) | 30 (762) | 30 (762) | 35 (889) | 34 (864) | --- | | | |
| | OFD-150 | H or V | 36 x 36 (914 x 914) | 36 x 31 (914 x 787) | --- | --- | --- | | | --- | | | |
| 3 Hour | FD-300 | V | 48 x 48 (1219 x 1219) | 48 x 40 (1219 x 1016) | --- | --- | --- | --- | --- | --- | | | |
| | FD-310 | V | 48 x 48 (1219 x 1219) | 48 x 42 (1219 x 1067) | --- | --- | --- | --- | --- | --- | | | |
| | FD-350 | V | 48 x 48 (1219 x 1219) | 48 x 42 (1219 x 1067) | 46 x 41 (1168 x 1041) | 41 (1041) | 30 (762) | 47 (1194) | 46 (1168) | --- | | | |
| | | H | 40 x 40 (1016 x 1016) | 40 x 35 (1016 x 889) | 38 x 34 (965 x 864) | 34 (864) | 30 (762) | 39 (991) | 38 (965) | 80 x 40 (2032 x 1016) | 80 x 35 (2032 x 889) | 78 x 34 (1981 x 964) | --- |
| | SSFD-350 | V | 48 x 48 (1219 x 1219) | 48 x 42 (1219 x 1067) | 46 x 41 (1168 x 1041) | 41 (1041) | 30 (762) | 47 (1194) | 46 (1168) | --- | | | |

*Multiple section size

Note: For round fire dampers, see page 39.

Maximum Damper Size Limitations

Dynamic Fire Dampers (1½ Hour) – Models and Sizes

Fire Dampers

| Model | Mounting Horizontal or Vertical (H or V) | Maximum | | | Maximum Size W x H, in inches (mm) | | | | | | | | |
|---------|--|---------------------|---------------------------|-----------------------|---|---|---|---|-----------|--------------|--------------|--------------|-----|
| | | Temperature °F (°C) | Velocity ft./min. (m/s) | Pressure in. wg (kPa) | No Transitions or A style | | B/B2 | C & CO | CR | R | | | |
| | | | | | Single Section | Multi section | | | | 0 in. offset | 1 in. offset | 2 in. offset | |
| DFD-110 | V | 165° (74°) | 2000 (10) | 4 (1) | 36 x 36 (914 x 914) | 72 x 48 (1829 x 1219) | 72 x 45 (1829 x 1143) | --- | --- | --- | --- | --- | --- |
| | | | 3000 (15.2) | | 30 x 30 (762 x 762) | --- | 30 x 26 (762 x 660) | | | | | | |
| | | | 4000 (20) | | 24 x 24 or 18 x 30 (610 x 610 or 457 x 762) | --- | 24 x 21 or 18 x 26 (610 x 533 or 457 x 660) | | | | | | |
| | H | 2000 (10) | 30 x 30 (762 x 762) | 48 x 36 (1219 x 914) | 48 x 33 (1219 x 838) | | | | | | | | |
| | V | 212° (100°) | 2000 (10) | 24 x 24 (610 x 610) | 48 x 36 or 18 x 48 (1219 x 914 or 457 x 1219) | 48 x 31 or 18 x 45 (1219 x 787 or 457 x 1143) | | | | | | | |
| | | | 3000 or 4000 (15.2 or 20) | 18 x 30 (457 x 762) | --- | 18 x 26 (457 x 660) | | | | | | | |
| | H | 2000 (10) | 24 x 24 (610 x 610) | 48 x 36 (1219 x 914) | 48 x 33 (1219 x 838) | | | | | | | | |
| | V | 286° (141°) | 2000 (10) | 24 x 24 (610 x 610) | 18 x 48 (457 x 1219) | 18 x 45 (457 x 1143) | | | | | | | |
| | | | 3000 or 4000 (15.2 or 20) | 18 x 30 (457 x 762) | --- | 18 x 26 (457 x 660) | | | | | | | |
| | H | 2000 (10) | 24 x 24 (610 x 610) | --- | 24 x 21 (610 x 533) | | | | | | | | |
| DFD-150 | V | 165° (74°) | 2000 (10) | 4 (1) | 36 x 36 (914 x 914) | 72 x 48, 60 x 60 or 120 x 30 (1829 x 1219, 1524 x 1524 or 3048 x 762) | 72 x 45, 60 x 58 or 120 x 26 (1829 x 1143, 1524 x 1422 or 3048 x 660) | 70 x 44, 58 x 55 or 118 x 25 (1778 x 1118, 1473 x 1397 or 2997 x 635) | 55 (1397) | 30 (762) | 59 (1499) | 58 (1473) | |
| | | | 3000 (15.2) | | 30 x 30 (762 x 762) | --- | 30 x 26 (762 x 660) | 28 x 25 (711 x 635) | 25 (635) | 30 (762) | 29 (737) | 28 (711) | |
| | | | 4000 (20) | | 24 x 24 or 18 x 30 (610 x 610 or 457 x 762) | --- | 24 x 21 or 18 x 26 (610 x 533 or 457 x 660) | 22 x 20 or 16 x 25 (559 x 508 or 406 x 635) | 20 (508) | 24 (610) | 23 (584) | 22 (559) | |
| | H | 2000 (10) | 30 x 30 (762 x 762) | | 48 x 36 (1219 x 914) | 48 x 33 (1219 x 838) | 46 x 32 (1168 x 813) | 32 (813) | 30 (762) | 35 (889) | 34 (864) | | |
| | V | 212° (100°) | 2000 (10) | | 24 x 24 or 18 x 30 (610 x 610 or 457 x 762) | 48 x 36 or 18 x 60 (1219 x 914 or 457 x 1524) | 48 x 31 or 18 x 56 (1219 x 787 or 457 x 1422) | 46 x 30 or 16 x 55 (1168 x 762 or 406 x 1397) | 30 (762) | 30 (762) | 35 (889) | 34 (864) | |
| | | | 3000 or 4000 (15.2 or 20) | | 18 x 30 (457 x 762) | --- | 18 x 26 (457 x 660) | 16 x 25 (406 x 635) | 16 (406) | 18 (457) | 17 (432) | 16 (406) | |
| | H | 2000 (10) | 24 x 24 (610 x 610) | | 48 x 36 (1219 x 914) | 48 x 33 (1219 x 838) | 46 x 32 (1168 x 813) | 32 (813) | 30 (762) | 35 (889) | 34 (864) | | |
| | V | 286° (141°) | 2000 (10) | | 24 x 24 or 18 x 30 (610 x 610 or 457 x 762) | 18 x 60 (457 x 1524) | 24 x 21 or 18 x 56 (610 x 533 or 457 x 1422) | 22 x 20 or 16 x 55 (559 x 508 or 406 x 1397) | 20 (508) | 24 (610) | 23 (584) | 22 (559) | |
| | | | 3000 or 4000 (15.2 or 20) | | 18 x 30 (457 x 762) | --- | 18 x 26 (457 x 660) | 16 x 25 (406 x 635) | 16 (406) | 18 (457) | 17 (432) | 16 (406) | |
| | H | 2000 (10) | 24 x 24 (610 x 610) | | --- | 24 x 21 (610 x 533) | 22 x 20 (559 x 508) | 20 (508) | 24 (610) | 23 (584) | 22 (559) | | |

Maximum Damper Size Limitations

Dynamic Fire Dampers (1½ Hour) – Models and Sizes

| Model | Mounting Horizontal or Vertical (H or V) | Maximum | | | Maximum Size W x H, in inches (mm) | | | | | | | | |
|--|--|---------------------|---------------------------|---|---|---------------------|---|---|----------|--------------|--------------|--------------|--|
| | | Temperature °F (°C) | Velocity ft./min. (m/s) | Pressure in. wg (kPa) | No Transitions or A style | | B/B2 | C & CO | CR | R | | | |
| | | | | | Single Section | Multi section | | | | 0 in. offset | 1 in. offset | 2 in. offset | |
| DFD-150X12 DFD-150X14 DFD-150X16 | V | 165° (74°) | 2000 (10) | 4 (1) | 36 x 36 (914 x 914) | --- | 36 x 31 (914 x 787) | 34 x 30 (864 x 762) | 30 (762) | 30 (762) | 35 (889) | 34 (864) | |
| | | | 3000 (15.2) | | 30 x 30 (762 x 762) | --- | 30 x 26 (762 x 660) | 28 x 25 (762 x 635) | 25 (635) | 30 (762) | 29 (737) | 28 (711) | |
| | | | 4000 (20) | | 24 x 24 (610 x 610) | --- | 24 x 21 or 18 x 26 (610 x 533 or 457 x 660) | 22 x 20 or 16 x 25 (559 x 508 or 406 x 635) | 22 (559) | 24 (610) | 23 (584) | 22 (559) | |
| | H | | 2000 (10) | | 30 x 30 (762 x 762) | --- | 30 x 26 (762 x 660) | 28 x 25 (711 x 635) | 25 (635) | 30 (762) | 29 (737) | 28 (711) | |
| | V | 212° (100°) | 2000 (10) | 4 (1) | 24 x 24 (610 x 610) | --- | 24 x 21 or 18 x 26 (610 x 533 or 457 x 660) | 22 x 20 or 16 x 25 (559 x 508 or 406 x 635) | 22 (559) | 24 (610) | 23 (584) | 22 (559) | |
| | | | 3000 or 4000 (15.2 or 20) | | 18 x 30 (457 x 762) | --- | 18 x 26 (457 x 660) | 16 x 25 (406 x 635) | 16 (406) | 18 (457) | 17 (432) | 16 (406) | |
| | H | | 2000 (10) | | 24 x 24 (610 x 610) | --- | 24 x 21 (610 x 533) | 22 x 20 (559 x 508) | 22 (559) | 24 (610) | 23 (584) | 22 (559) | |
| | V | 286° (141°) | 2000 (10) | 4 (1) | 24 x 24 (610 x 610) | --- | 24 x 21 or 18 x 26 (610 x 533 or 457 x 660) | 22 x 20 or 16 x 25 (559 x 508 or 406 x 635) | 22 (559) | 24 (610) | 23 (584) | 22 (559) | |
| | | | 3000 or 4000 (15.2 or 20) | | 18 x 30 (457 x 762) | --- | 18 x 26 (457 x 660) | 16 x 25 (406 x 635) | 16 (406) | 18 (457) | 17 (432) | 16 (406) | |
| | H | | 2000 (10) | | 24 x 24 (610 x 610) | --- | 24 x 21 (610 x 533) | 22 x 20 (559 x 508) | 22 (559) | 24 (610) | 23 (584) | 22 (559) | |
| | ODFD-150 | V | 165° (74°) | 2000 (10) | 4 (1) | 36 x 36 (914 x 914) | --- | 36 x 31 (914 x 787) | | --- | | | |
| | | | | 3000 (15.2) | | 30 x 30 (762 x 762) | --- | 30 x 26 (762 x 660) | | --- | | | |
| 4000 (20) | | | | 24 x 24 or 18 x 30 (610 x 610 or 457 x 762) | | --- | 24 x 21 or 18 x 26 (610 x 533 or 457 x 660) | | --- | | | | |
| H | | | 2000 (10) | | 30 x 30 (762 x 762) | 36 x 36 (914 x 914) | 36 x 31 (914 x 787) | | --- | | | | |
| V | | 212° (100°) | 2000 (10) | 4 (1) | 24 x 24 or 18 x 30 (610 x 610 or 457 x 762) | 36 x 36 (914 x 914) | 36 x 31 (914 x 787) | | --- | | | | |
| | | | 3000 or 4000 (15.2 or 20) | | 18 x 30 (457 x 762) | --- | 18 x 26 (457 x 660) | | --- | | | | |
| H | | | 2000 (10) | | 24 x 24 (610 x 610) | 36 x 36 (914 x 914) | 36 x 31 (914 x 787) | | --- | | | | |
| V | | 286° (141°) | 2000 (10) | 4 (1) | 24 x 24 or 18 x 30 (610 x 610 or 457 x 762) | 36 x 36 (914 x 914) | 36 x 31 (914 x 787) | | --- | | | | |
| | | | 3000 or 4000 (15.2 or 20) | | 18 x 30 (457 x 762) | --- | 18 x 26 (457 x 660) | | --- | | | | |
| H | | | 2000 (10) | | 24 x 24 (610 x 610) | --- | 24 x 21 (610 x 533) | | --- | | | | |
| SSDFD-150 | | V | Up to 212° (100°) | 4 (1) | 30 x 30 (762 x 762) | --- | 30 x 26 (762 x 660) | 28 x 25 (711 x 635) | 25 (635) | 30 (762) | 29 (737) | 28 (711) | |
| | | | 286° (141°) | | 24 x 24 (610 x 610) | --- | 24 x 21 (610 x 533) | 22 x 20 (559 x 508) | 20 (508) | 24 (610) | 23 (584) | 22 (559) | |



Maximum Damper Size Limitations

Dynamic Fire Dampers (3 Hour) – Models and Sizes

Fire Dampers

| Model | Mounting Horizontal or Vertical (H or V) | Maximum | | | Maximum Size W x H, in inches (mm) | | | | | | | | |
|---------|--|---------------------|---------------------------|-----------------------|---|---|---|---|---------------------|--------------|--------------|--------------|----------|
| | | Temperature °F (°C) | Velocity ft/min. (m/s) | Pressure in. wg (kPa) | No Transitions or A style | | B/B2 | C & CO | CR | R | | | |
| | | | | | Single Section | Multi section | | | | 0 in. offset | 1 in. offset | 2 in. offset | |
| DFD-310 | V | 165° (74°) | 2000 (10) | 4 (1) | 36 x 36 (914 x 914) | 48 x 48 (1219 x 1219) | 48 x 45 (1219 x 1143) | --- | --- | --- | --- | --- | --- |
| | | | 3000 (15.2) | 4 (1) | 30 x 30 (762 x 762) | --- | 30 x 26 (762 x 660) | | | | | | |
| | | | 4000 (20) | 4 (1) | 24 x 24 or 18 x 30 (610 x 610 or 457 x 762) | --- | 24 x 21 or 18 x 26 (610 x 533 or 457 x 660) | | | | | | |
| | H | | 2000 (10) | 4 (1) | 30 x 30 (762 x 762) | 40 x 36 (1016 x 914) | 40 x 33 (1016 x 838) | | | | | | |
| | V | 212° (100°) | 2000 (10) | 4 (1) | 24 x 24 (610 x 610) | 48 x 36 or 18 x 48 (1219 x 914 or 457 x 1219) | 48 x 31 or 18 x 45 (1219 x 787 or 457 x 1143) | | | | | | |
| | | | 3000 or 4000 (15.2 or 20) | 4 (1) | 18 x 30 (457 x 762) | --- | 18 x 26 (457 x 660) | | | | | | |
| | H | | 2000 (10) | 4 (1) | 24 x 24 or 18 x 30 (610 x 610 or 457 x 762) | 40 x 36 (1016 x 914) | 40 x 33 (1016 x 838) | | | | | | |
| | V | 286° (141°) | 2000 (10) | 4 (1) | 24 x 24 (610 x 610) | 18 x 48 (457 x 1219) | 18 x 45 (457 x 1143) | | | | | | |
| | | | 3000 or 4000 (15.2 or 20) | 4 (1) | 18 x 30 (457 x 762) | --- | 18 x 26 (457 x 660) | | | | | | |
| H | | 2000 (10) | 4 (1) | 24 x 24 (610 x 610) | --- | 24 x 21 or 18 x 26 (610 x 533 or 457 x 660) | | | | | | | |
| DFD-350 | V | 165° (74°) | 2000 (10) | 4 (1) | 36 x 36 (914 x 914) | 48 x 48 (1219 x 1219) | 48 x 45 (1219 x 1143) | 46 x 44 (1168 x 1118) | 44 (1118) | 30 (762) | 47 (1194) | 46 (1168) | |
| | | | 3000 (15.2) | 4 (1) | 30 x 30 (762 x 762) | --- | 30 x 26 (762 x 660) | 28 x 25 (711 x 635) | 25 (635) | 30 (762) | 29 (737) | 28 (711) | |
| | | | 4000 (20) | 4 (1) | 24 x 24 or 18 x 30 (610 x 610 or 457 x 762) | --- | 24 x 21 or 18 x 26 (610 x 533 or 406 x 635) | 22 x 20 or 16 x 25 (559 x 508 or 406 x 635) | 20 (508) | 24 (610) | 23 (584) | 22 (559) | |
| | H | | 2000 (10) | 4 (1) | 30 x 30 (762 x 762) | 40 x 36 (1016 x 914) | 40 x 33 (1016 x 914) | 38 x 32 (965 x 813) | 32 (813) | 30 (762) | 35 (889) | 34 (864) | |
| | V | 212° (100°) | 2000 (10) | 4 (1) | 24 x 24 (610 x 610) | 48 x 36 or 18 x 48 (1219 x 914 or 457 x 1219) | 48 x 31 or 18 x 45 (1219 x 787 or 457 x 1143) | 46 x 30 or 16 x 44 (1168 x 762 or 406 x 1118) | 30 (762) | 30 (762) | 35 (889) | 34 (864) | |
| | | | 3000 or 4000 (15.2 or 20) | 4 (1) | 18 x 30 (457 x 762) | --- | 18 x 26 (457 x 660) | 16 x 25 (406 x 635) | 16 (406) | 18 (457) | 17 (432) | 16 (406) | |
| | H | | 2000 (10) | 4 (1) | 30 x 30 (762 x 762) | 40 x 36 (1016 x 914) | 40 x 33 (1016 x 914) | 38 x 32 (965 x 813) | 32 (813) | 30 (762) | 35 (889) | 34 (864) | |
| | V | 286° (141°) | 2000 (10) | 4 (1) | 24 x 24 (610 x 610) | 18 x 48 (457 x 1219) | 24 x 21 or 18 x 45 (610 x 533 or 457 x 1143) | 22 x 20 or 16 x 44 (559 x 508 or 406 x 1118) | 20 (508) | 24 (610) | 23 (584) | 22 (559) | |
| | | | 3000 or 4000 (15.2 or 20) | 4 (1) | 18 x 30 (457 x 762) | --- | 18 x 26 (457 x 660) | 16 x 25 (406 x 635) | 16 (406) | 18 (457) | 17 (432) | 16 (406) | |
| | H | | 2000 (10) | 4 (1) | 24 x 24 (610 x 610) | --- | 24 x 21 (610 x 533) | 22 x 20 (559 x 508) | 20 (508) | 24 (610) | 23 (584) | 22 (559) | |
| | SSDFD-350 | V | up to 212° (100°) | 2000 (10) | 4 (1) | 30 x 30 (762 x 762) | --- | 30 x 26 (762 x 660) | 28 x 25 (711 x 635) | 25 (635) | 30 (762) | 29 (737) | 28 (711) |
| | | | 286° (141°) | 2000 (10) | 4 (1) | 24 x 24 (610 x 610) | --- | 24 x 21 (610 x 533) | 22 x 20 (559 x 508) | 20 (508) | 24 (610) | 23 (584) | 22 (559) |

Maximum Damper Size Limitations

Multi-Blade Dynamic Fire Dampers – Models and Sizes

| Model | Mounting Horizontal or Vertical (H or V) | Maximum | | | Maximum Sizes H or V Installation, in inches (mm) | | | | | | |
|----------------------|---|-------------------------|------------------------------|-----------------------------|--|----------------------------|--|--|--|-----------------|--------------|
| | | Temperature °F (°C) | Velocity ft/min. (m/s) | Pressure in. wg (kPa) | No Transitions | | C & O | R | | | |
| | | | | | Single Section Size | Multi section | | 0 in. offset | 1 in. offset | 2 in. offset | |
| DFD-210 | H | Up to 286° (141°) | 2000 (10) | 4 (1) | 32 x 50 (813 x 1270) | 128 x 96 (3251 x 2438) | C: 92 x 82 (2337 x 2083) O: 92 x 80 (2337 x 2032) | 30 (762) | 83 (2108) | 82 (2083) | |
| | | Up to 350° (177°) | | | 36 x 36 (914 x 914) | --- | 34 x 34 (864 x 864) | 30 (762) | 35 (889) | 34 (864) | |
| | V | Up to 286° (141°) | | | 32 x 50 (813 x 1270) | 128 x 100 (3251 x 2540) | C: 92 x 82 (2337 x 2083) O: 92 x 80 (2337 x 2032) | 30 (762) | 83 (2108) | 82 (2083) | |
| | | Up to 350° (177°) | | | 36 x 36 (914 x 914) | --- | 34 x 34 (864 x 864) | 30 (762) | 35 (889) | 34 (864) | |
| | H or V | Up to 212° (100°) | | | 10 (2.5) | 32 x 50 (813 x 1270) | 64 x 50 (1626 x 1270) | 62 x 48 (1575 x 1219) | 30 (762) | 49 (1245) | 48 (1219) |
| | | Up to 350° (177°) | | | | 36 x 36 (914 x 914) | --- | 34 x 34 (864 x 864) | 30 (762) | 35 (889) | 34 (864) |
| | | Up to 212° (100°) | 4000 (20) | 10 (2.5) | 32 x 50 (813 x 1270) | --- | 30 x 48 (762 x 1219) | 30 (762) | 31 (787) | 30 (762) | |
| | SEDFD-210 | H or V | Up to 350° (177°) | 2000 (10) | 4 (1) | 24 x 30 (610 x 762) | 48 x 30 (1219 x 762) | 46 x 28 (1168 x 711) | 30 (762) | 29 (737) | 28 (711) |
| | DFDAF-310 | H | Up to 350° (177°) | 2000 (10) | 4 (1) | 32 x 50 (813 x 1219) | 144 x 96 (3658 x 2438) | C: 92 x 82 (2337 x 2083) O: 92 x 80 (2337 x 2032) | 30 (762) | 83 (2108) | 82 (2083) |
| | | | V | | | Up to 286° (141°) | 32 x 50 (813 x 1219) | 128 x 100 (3251 x 2540) | C: 92 x 82 (2337 x 2083) O: 92 x 80 (2337 x 2032) | 30 (762) | 83 (2108) |
| Up to 350° (177°) | | 32 x 50 (813 x 1219) | | | | 96 x 50 (2438 x 1219) | 92 x 48 (2337 x 1219) | 30 (762) | 49 (1245) | 48 (1219) | |
| H or V | | Up to 350° (177°) | 4000 (20) | 8 (2) | 32 x 50 (813 x 1219) | --- | 30 x 48 (762 x 1219) | 30 (762) | 31 (787) | 30 (762) | |
| DFDAF-330 | V | Up to 286° (141°) | 2000 (10) | 4 (1) | 32 x 36 or 30 x 48 (813 x 914 or 762 x 1219) | 120 x 96 (3048 x 2438) | C: 92 x 82 (2337 x 2083) O: 92 x 80 (2337 x 2032) | 30 (762) | 83 (2108) | 82 (2083) | |
| | | Up to 350° (177°) | | | 32 x 36 or 30 x 48 (813 x 914 or 762 x 1219) | 32 x 48 (813 x 1219) | 30 x 46 (762 x 1219) | 30 (762) | 31 (787) | 30 (762) | |
| | H | Up to 286° (141°) | | | 30 x 48 (762 x 1219) | 144 x 96 (3658 x 2438) | C: 92 x 82 (2337 x 2083) O: 92 x 80 (2337 x 2032) | 30 (762) | 83 (2108) | 82 (2083) | |
| | | Up to 350° (177°) | | | 30 x 48 (762 x 1219) | 32 x 48 (813 x 1219) | 30 x 46 (762 x 1168) | 30 (762) | 31 (787) | 30 (762) | |
| | H or V | Up to 350° (177°) | 4000 (20) | 8 (2) | 30 x 48 (762 x 1219) | --- | 28 x 46 (711 x 1168) | 30 (762) | 29 (737) | 28 (711) | |

Fire
Dampers

Smoke Dampers

Application

Smoke dampers are required to close and resist the passage of smoke through ducts or air transfer openings in smoke barriers.

Smoke dampers have two general applications. They may be applied in a “Passive Smoke Control System” where they simply close to minimize the passage of smoke through a duct or ventilation opening in a smoke barrier. They also may be applied as part of an “Engineered Smoke Control System” designed to control the spread of smoke using the building’s HVAC system and/or dedicated fans to create pressure differences. Higher pressures surround the fire zone and prevent the spread of smoke from the fire zone into other areas of the building. Smoke dampers are also used in air handling equipment for isolation.

Smoke dampers are motorized with electric or pneumatic actuators and are controlled by a smoke detector or a smoke control system to accomplish the intent of the design.

UL Classified smoke dampers are tested to UL Standard 555S “Smoke Dampers”. It is necessary to determine the following ratings when applying a UL smoke damper:

- **Leakage:** Class I (lowest leakage), Class II, or Class III (highest leakage). The 2015 International Building Code (IBC), section 717.3.2 requires a minimum of Leakage Class II. Leakage Class I is recommended to provide the safest level of protection.
- **Elevated Temperature:** 250°F or 350°F (121°C or 177°C) is the temperature at which the actuator must be able to operate the damper and the temperature at which the leakage test is conducted. Most often 350°F (177°C) is selected for the highest level of safety.
- **Velocity and Pressure:** UL 555S requires each smoke damper with its installed actuator to be rated for operation to open against a specific pressure differential (in. wg) and to close against a specific velocity of airflow (ft/min). Dampers should be selected to operate at the pressures and velocities they will be exposed to in their application, with a minimum of 4 in. wg (1 kPa) and 2000 ft/min (10.2 m/s).



Typical Smoke Damper

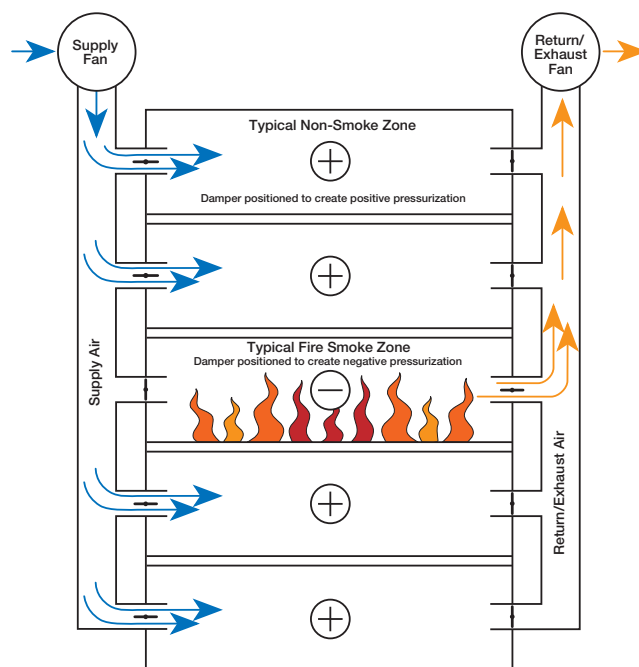

Typical Engineered Smoke Control System
Smoke is contained to the fire zone by higher pressures in adjacent zones

UL Standards for Testing and Rating of Smoke Dampers

UL (Underwriters Laboratories) Classified smoke dampers are tested to UL Standard 555S “Smoke Dampers”. They are always supplied with an appropriate UL label. Below are some of the test requirements that UL 555S classified dampers are subject to.

Cycle Test (UL 555S)

UL classified smoke dampers are cycled open and closed (by their actuator) 20,000 times. Smoke dampers that are also intended for use as a volume control damper must be cycled open and closed 100,000 repositioning cycles. These cycling tests are performed prior to all other tests (described below) and ensure that the damper will function reliably after repeated operations.

Salt Spray Exposure Test (UL 555 & UL 555S)

A damper sample is exposed to salt spray in a test chamber for a period of 120 hours. After this exposure, the damper must close (and latch if a latch is provided). The purpose of this test is to make sure the damper operates after build-up.

Operational Test (UL 555S)

During an operation test a smoke damper and actuator assembly must demonstrate the ability to operate under the velocity and pressure conditions for which it is rated. The assembly must cycle three times under ambient conditions and then one time after being exposed to the rated temperature (250°F or 350°F) for 15 minutes.

Temperature Degradation Test (UL 555S)

A damper with an actuator that has previously been subjected to the Operational Test (described above) is exposed to an elevated temperature of 250°F (121°C) minimum (or higher in multiples of 100°F [38°C]) for a period of 30 minutes. After 30 minutes exposure and while still at the elevated temperature, the damper actuator must operate the damper open and closed three times. Time of operation cannot exceed 75 seconds for any of the open or closed operations.

Leakage Test (UL 555S)

At least three damper sizes of each model being tested (minimum width by maximum height, maximum width by minimum height, and maximum width by maximum height) that have previously been subjected to both the Cycle Test and the Temperature Degradation Test must be tested for leakage. The minimum airflow and pressure ratings of dampers shall be 2000 ft/min (10.2 m/s) and 4 in. wg. (1 kPa). Ratings shall be set in 1000 ft/min (5 m/s) increments from the minimum airflow and in 2 in. wg (0.5 kPa) increments from the minimum pressure. A damper’s leakage rating is based on the worst-case performance of the three damper sizes tested.

| Leakage Class | Maximum Leakage in cfm/ft ² | | Maximum Leakage in cmh/m ² | |
|---------------|--|------------|---------------------------------------|---------|
| | @ 4 in. wg | @ 8 in. wg | @ 1 kPa | @ 2 kPa |
| Class I | 8 | 11 | 146 | 201 |
| Class II | 20 | 28 | 366 | 512 |
| Class III | 80 | 112 | 1463 | 2048 |

Installation

The IBC (International Building Code) requires life safety dampers to be installed in accordance with the manufacturer's installation instructions and the damper's listing.

UL (Underwriters Laboratories) requires all fire, smoke, and combination fire smoke damper manufacturers to publish specific damper installation instructions detailing the required installation methods and procedures to properly install each specific model of damper. These instructions must be followed to maintain the validity of the damper's UL listing. A copy of the appropriate installation instruction(s) is included with each shipment of UL fire, smoke, or combination fire smoke dampers. Installation requirements may differ between damper manufacturers as a manufacturer may qualify alternate installation methods by conducting additional tests. Dampers must be installed in accordance with instructions published by the company that manufactured the dampers.

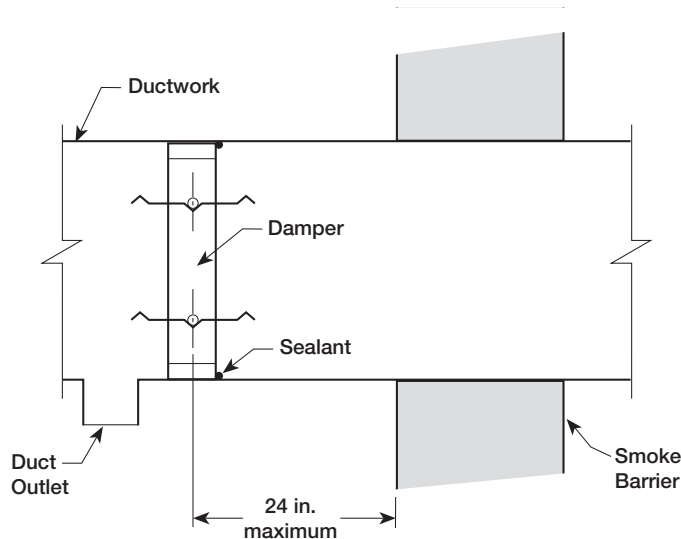

Location of Damper

The centerline of the damper blades must be within 24 in. (610mm) of the rated smoke barrier and before any duct inlets or outlets.

Attaching Damper to the Duct

Attach the damper to the duct using sheet metal screws, bolts and nuts, tack or spot weld, or pop rivets. Attachments must be made per installation instructions to sleeve or sideplate.

Sealing the Damper Frame to the Ductwork

After installing the damper, seal the joint between the damper and ductwork using UL approved sealant. This prevents unwanted air leakage. This is required for Class I leakage. Sealing the damper frame and ductwork is optional for Class II or III dampers.

Actuator

Factory installation of actuators on smoke and combination fire smoke dampers is required by UL 555S.

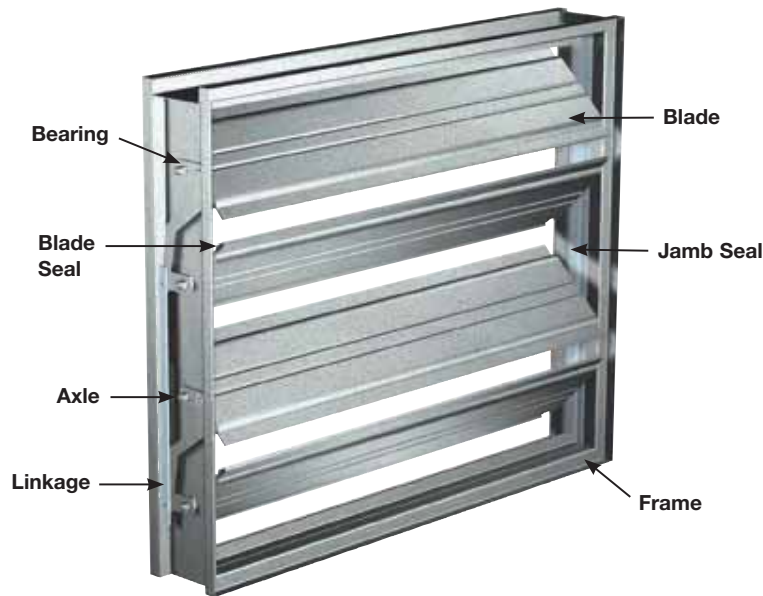

Frame - Tog-L-Loc® Advantage

Greenheck smoke dampers utilize a 5 in. x 1 in. (127mm x 25mm) hat channel frame. Each frame is built with four separate pieces of material and joined by our Tog-L-Loc® process. The Tog-L-Loc® process provides a more rigid frame that resists “racking” better than welded construction.



**Tog-L-Loc®
Reinforced Corner**

Frame Options

The frame options available are:

- **Channel (standard)** - allows damper to be insert mounted into an opening or duct
- **Single flange or single reverse flange (SMD-401EF only)** - can be insert mounted or directly mounted to the wall or mating surfaces such as a plenum wall.

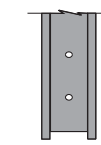

Channel Frame
(for inserting in duct)

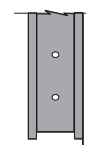

Single Flange
(actuator side)

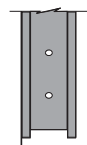

Single Reverse Flange
(opposite actuator)

Maximize Performance - Low Profile Frame

On dampers that are 17 in. (432mm) high or less, Greenheck uses a low profile top and bottom frame to maximize free area, allowing for lower pressure drop and increased damper performance.



Construction

Blades



3V Blade

- Fabricated from a single thickness galvanized steel or stainless steel
- Three V-type grooves running the full length of the blade to increase strength
- Low to medium velocity and pressure applications



Steel Airfoil Blade

- Constructed of double-skin galvanized steel
- This blade design results in lower resistance to airflow and increased strength
- High velocity and pressure applications



Aluminum Airfoil Blade

- Constructed of heavy gauge extruded aluminum
- This blade design results in lower resistance to airflow and increased strength
- High velocity and pressure applications

Variable Symmetric Blade Design (VSB) - a Greenheck Exclusive!

- Blades are symmetric about their axis
- Combination of 4, 5, 6, and 7 in. (102, 127, 152, and 178mm) blade widths are used in a single damper
- Reduces the need for closure strips which optimize pressure drop performances
- Damper is bi-directional airflow rated
- Through extensive testing of our dampers, we have determined using various blade sizes reduces required actuator torque which reduces the size and quantity of actuators used on dampers. This reduces first costs for the building owner and on-going electrical power consumption.

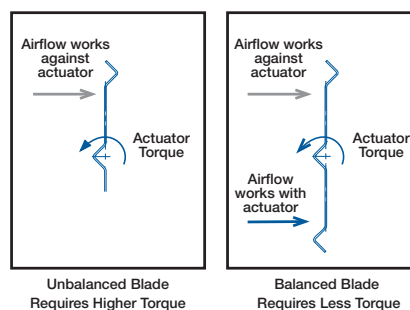

Seals

Seals are used for low leakage applications.

- **Blade seals:** Silicone
- **Jamb seals:** Jamb seals are constructed of flexible 304SS compression type material to help reduce leakage along the blade edges.



Linkage

Greenheck smoke dampers have blade linkages concealed in the frame to prevent additional pressure drop and unwanted noise. The linkage is engineered to accurately control each and every blade without need for adjustment.



Bearings

- 304SS - Standard
- 316SS - Used on SESMD and SEFSD series

A variety of electric and pneumatic actuators are available for all damper models. Each actuator-damper combination is UL Classified to operate up to specific maximum velocities and pressures, with ratings as high as 4000 ft/min. (20 m/s) and 8 in. wg (2 kPa). Actuators can be mounted internally or externally.

Under UL 555 and UL 555S testing, the damper and its installed actuator must be tested as an assembly. Actuators must be furnished factory-installed by the damper manufacturer. Modulating actuators are available for variable volume applications.

Electric Actuator Checklist

See Figures 1 and 2

Power Supply

- 24, 120, or 240 VAC
- Frequency in Hz

Operation

- Two position (damper position is open or closed)
- Modulating (damper position determined by modulating control signal)

Fail Direction

- Open or close

Mounting Location

- Internal or external to the sleeve/ductwork

Control Signal (for modulating only)

- 0/2-10 VDC, 4-20 mA

NEMA Enclosure

- 1 or 7 (specify one for specific application)

Accessories

- Auxiliary switches (end switches built into actuator)
- Transformer

Pneumatic Actuator Checklist

See Figure 3

Air Pressure

- 20 or 25 psi

Operation

- Two position (damper position is open or closed)
- Modulating (damper position determined by modulating pressure signal)

Fail Direction

- Open or close

Mounting Location

- Internal or external to the sleeve/ductwork

Control Signal (for modulating only)

- Control pressure start point and operating span are field adjustable

Accessories

- Solenoid valve



Figure 1



Figure 2



Figure 3

Greenheck offers a wide variety of electric actuators for installation external or internal to the sleeve/ductwork.

Greenheck also offers pneumatic actuator options.

Actuator Mounting

Actuators must be factory mounted. Factory mounting options may be external (on a damper sleeve or sideplate) or internal. Internal actuator mounting (where the actuator is mounted in the airstream) should be avoided if possible, as it increases pressure drop and the difficulty of actuator inspecting, testing, and servicing.

Factory Mounting - External on a Sleeve

As all combination fire smoke dampers require a sleeve for proper installation, the most practical choice is for the damper to be furnished by the factory, complete with a sleeve and the actuator installed on the outside of the sleeve. This is the standard and recommended actuator mounting option for combination fire smoke dampers.

Factory Mounting - External on a Sideplate

Smoke dampers do not require sleeves for proper installation. External installation of the actuator can be provided using a sideplate. These dampers are installed in a slotted duct section with the sideplate covering the slot in the side of the duct.

Factory Mounting - Internal

Most actuators can be mounted internally (in the airstream) to accommodate installations where space constraints prevent the more desirable external installation. There are limitations on small sizes with options (such as the TOR, RRL/OCI, OCI or PRV), which occupy much of the available internal space.



Damper mounted in sleeve with actuator externally mounted.

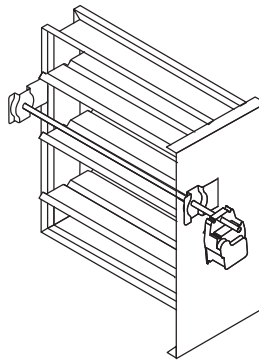

Damper with sideplate actuator externally mounted.



Damper mounted in sleeve with actuator internally mounted.

Vertical Blade

Vertical blade dampers allow the installer to mount the actuator externally on the top or bottom of the damper when obstructions prevent installation with the actuator mounted on the sides. The SMD-301V and FSD-311V have a Class I leakage rating and 350°F (177°C) temperature rating.



Quick Reference Guide

| | Frame | | | | | Blade Profile | | | Leakage Class | | | Accessories | | | | | |
|--|---|---------------------|---------------------|----------|---|---------------|---------------|------------------|---------------|----------|-----------|------------------|----------------|--------------------|-------------------------------|-------------|-----------------------------|
| | 5 x 1 in. x 16 ga. Galvanized Steel Hat Channel | 304 Stainless Steel | 316 Stainless Steel | Aluminum | 8 x 2 in. x 12 ga. Galvanized Steel Hat Channel | 3V | Steel Airfoil | Aluminum Airfoil | Class I | Class II | Class III | Retaining Angles | Smoke Detector | Momentary Switches | Open or Close Indicator (OCI) | Transformer | Greenheck Test Switch (GTS) |
| X = Standard O = Optional | | | | | | | | | | | | | | | | | |
| SMD-201 | X | | | | | X | | | X | | | O | O | O | O | O | O |
| SMD-201M | X | | | | | X | | | X | | | O | O | O | O | O | O |
| SMD-202 | X | | | | | X | | | | X | | O | O | O | O | O | O |
| SMD-203 | X | | | | | X | | | | | X | O | O | O | O | O | O |
| SSSMD-201 | | X | | | | X | | | X | | | O | O | O | O | O | O |
| SESMD-201 | | | X | | | X | | | X | | | O | O | O | O | O | O |
| SMD-301 | X | | | | | | X | | X | | | O | O | O | O | O | O |
| SMD-301M | X | | | | | | X | | X | | | O | O | O | O | O | O |
| SMD-301V | X | | | | | | X | | X | | | O | O | O | O | O | O |
| SMD-302 | X | | | | | | X | | | X | | O | O | O | O | O | O |
| SMD-302M | X | | | | | | X | | | X | | O | O | O | O | O | O |
| SMD-401 | X | | | | | | | X | X | | | O | O | O | O | O | O |
| SMD-401EF | | | | X | | | | X | X | | | O | O | O | O | O | O |
| SMD-401M | X | | | | | | | X | X | | | O | O | O | O | O | O |
| HSD-401 | | | | | X | | | X | X | | | O | O | O | O | O | O |

Smoke Dampers



SMD-201



SMD-301V



HSD-401

Maximum Damper Size Limitations

| Model | Leakage Class | Size Limitations - W x H, in inches (mm) | | | | | | Maximum | | |
|-------------------------------|--|--|--|-----------------------|--|--|--|--------------------------------|------------------------------|-----------------------------|
| | | Single Section | | | | Multi section | | Temperature Ratings °F (°C) | Velocity ft/min. (m/s) | Pressure in. wg (kPa) |
| | | Horizontal | | Vertical | | Horizontal | Vertical | | | |
| | | Minimum | Maximum | Minimum | Maximum | Maximum | | | | |
| SMD-201 SMD-202 SMD-203 | I II III | 8 x 6 (203 x 152) | 32 x 50 or 36 x 48 (813 x 1270 or 914 x 1219) | 8 x 6 (203 x 152) | 32 x 50 or 36 x 48 (813 x 1270 or 914 x 1219) | 144 x 100 or 288 x 50 (3658 x 2540 or 7315 x 1270) | 144 x 100 or 288 x 50 (3658 x 2540 or 7315 x 1270) | 350° (177°) | 2000 (10.2) | 4 (1) |
| | 36 x 48 (914 x 1219) | | 36 x 48 (914 x 1219) | | 144 x 48 (3658 x 1219) | 144 x 48 (3658 x 1219) | 6 (1.5) | | | |
| SMD-201M | I | 8 x 6 (203 x 152) | 36 x 36 (914 x 914) | 8 x 6 (203 x 152) | 36 x 36 (914 x 914) | 36 x 72 (914 x 1829) | 36 x 72 (914 x 1829) | 250° (121°) | 2000 (10.2) | 4 (1) |
| SESMD-201 SSSMD-201 | I | 8 x 6 (203 x 152) | 24 X 30 (610 x 762) | 8 x 6 (203 x 152) | 24 x 30 (610 x 762) | 88 x 72 (2235 x 1829) | 88 x 72 (2235 x 1829) | 350° (177°) | 2000 (10.2) | 4 (1) |
| | 88 x 48 (2235 x 1219) | | | | | 88 x 48 (2235 x 1219) | 6 (1.5) | | | |
| SMD-301 SMD-302 | I II | 8 x 6 (203 X 152) | 32 x 50 (813 x 1270) | 8 x 6 (203 x 152) | 32 x 50 (813 x 1270) | 192 x 100 (4877 x 2540) | 192 x 100 (3251 x 2540) | 350° (177°) | 2000 (10.2) | 4 (1) |
| | 192 x 72 or 128 x 100 (4877 x 1270 or 3251 x 2540) | | | | | 192 x 72 or 128 x 100 (4877 x 1270 or 3251 x 2540) | 8 (2) | | | |
| | 192 x 72 or 128 x 100 (4877 x 1270 or 3251 x 2540) | | | | | 192 x 72 or 128 x 100 (4877 x 1270 or 3251 x 2540) | 3000 (15.2) | | | 8 (2) |
| | 192 x 50 (4877 x 1270) | | | | | 192 x 50 (4877 x 1270) | 4000 (20.3) | | | 4 (1) |
| SMD-301M SMD-302M | I II | 8 x 6 (203 x 152) | 32 x 50 (813 x 1270) | 8 x 6 (203 x 152) | 32 x 50 (813 x 1270) | 128 x 100 (3251 x 2540) | 128 x 100 (3251 x 2540) | 250° (121°) | 2000 (10.2) | 4 (1) |
| SMD-301V | I | -- | -- | 6 x 8 (152 x 203) | 50 x 32 (1270 x 813) | -- | 100 x 32 (2540 x 813) | 350° (177°) | 2000 (10.2) | 4 (1) |
| | | | | | | -- | -- | | 4000 (20.3) | 4 (1) |
| SMD-401 | I | 8 x 8 (203 x 203) | 48 x 60 (1219 x 1524) | 8 x 8 (203 x 203) | 48 x 60 (1219 x 1524) | 192 x 120 (4877 x 3048) | 192 x 120 (4877 x 3048) | 250° (121°) | 2000 (10.2) | 4 (1) |
| | 48 x 36 (1219 x 914) | | 48 x 36 (1219 x 914) | | 192 x 72 (4877 x 1829) | 192 x 72 (4877 x 1829) | 3000 (15.2) | | | 6 (1.5) |
| SMD-401EF | I | 8 x 6 (203 x 152) | 48 x 48 (1219 x 1219) | 8 x 6 (203 x 152) | 48 x 48 (1219 x 1219) | 192 x 120 (4877 x 3048) | 192 x 120 (4877 x 3048) | 250° (121°) | 2000 (10.2) | 4 (1) |
| | 36 x 48 (914 x 1219) | | 36 x 48 (914 x 1219) | | 144 x 96 (3658 x 2438) | 144 x 96 (3658 x 2438) | 3000 (15.2) | | | 6 (1.5) |
| SMD-401M | I | 8 x 8 (203 x 203) | 36 x 36 (914 x 914) | 8 x 8 (203 x 203) | 36 x 36 (914 x 914) | 36 x 72 (914 x 1829) | 36 x 72 (914 x 1829) | 250° (121°) | 2000 (10.2) | 4 (1) |
| HSD-401 | I | 6 x 6¼ (152 x 159) | 60 x 60 (1524 x 1524) | 6 x 6¼ (152 x 159) | 60 x 60 (1524 x 1524) | 240 x 120 (6096 x 3048) | 240 x 120 (6096 x 3048) | 250° (121°) | 3000 (15.2) | 6 (1.5) |

Smoke Dampers

Combination Fire Smoke Dampers

Application

A combination fire smoke damper performs the function of both a fire damper and a smoke damper. Building layouts and designs often combine fire and smoke rated partitions and barriers requiring the installation of both a fire damper and smoke damper at the same location. Combination fire smoke dampers must be qualified under UL Standard 555 as a fire damper AND under UL Standard 555S as a smoke damper. The considerations listed in the fire damper and smoke damper sections apply to the selection and application of combination fire smoke dampers.

It is necessary to determine the following ratings when applying an UL combination fire smoke damper:

- Hourly Fire Rating: 1½ or 3 hour
- Leakage: Class I, II, or III
- Elevated Temperature: 250° or 350°F
- Velocity and Pressure: Minimum of 4 in. wg and 2000 fpm



Typical Combination Fire Smoke Damper

UL Standards for Testing and Rating Combination Fire Smoke Dampers

UL (Underwriters Laboratories) Classified combination fire smoke dampers are tested to UL Standard 555 “Fire Dampers” and UL 555S “Smoke Dampers”. They are always supplied with an appropriate UL label.

Below are some of the test requirements that UL 555 and UL 555S classified dampers are subjected to.

- Fire Endurance Test and Hose Stream Test (UL555)
- Dynamic Closure Test (UL555)
- Salt Spray Exposure Test (UL 555 and UL 555S)
- Cycling Test (UL 555 and UL 555S)
- Operational Test (UL 555S)
- Temperature Degradation Test (UL 555S)
- Leakage Test (UL 555S)

For more information on these tests, refer to the Fire Damper and the Smoke Damper section, page 6 and 21, respectively.

Installation

The IBC (International Building Code) requires life safety dampers to be installed in accordance with the manufacturer's installation instructions and the damper's listing.

UL requires all fire, smoke, and combination fire smoke damper manufacturers to publish specific damper installation instructions detailing the required installation methods and procedures to properly install each specific model of damper. These instructions must be followed to maintain the validity of the damper's UL listing. A copy of the appropriate installation instruction(s) is included with each shipment of UL fire, smoke, or combination fire smoke dampers. Installation requirements may differ between damper manufacturers as a manufacturer may qualify alternate installation methods by conducting additional tests. Dampers must be installed in accordance with instructions published by the company that manufactured the dampers.

Mounting Orientation

Combination fire smoke dampers are required to pass separate tests for vertical mount and horizontal mounting applications. Dampers need to be installed in the correct orientation to ensure life safety and proper fire protection. Every combination fire smoke damper is supplied with a label calling out the required mounting orientation.

Vertical mount dampers must be installed in masonry, block, or stud walls. Horizontal mount must be installed in concrete floors except when using the I503 horizontal non-concrete application (see Special Installations in the fire damper section).

Refer to the fire damper installation section (pages 7-9) for the following guidelines:

- Clearance required between damper sleeves and wall or floor openings
- Sleeve requirements
- Installing damper/sleeve assembly in wall and floor openings
- Duct-to-sleeve connection

Refer to the smoke damper installation section (page 22) for the following guidelines:

- Sealing the damper frame to the ductwork
- Actuator

Corridor Ceiling Fire Smoke Damper

UL has established a separate classification to list dampers for this application. UL 555 and 555S qualification plus additional tests in actual corridor ceiling construction are required by UL to classify as a corridor combination fire smoke damper.

They are available in three different installation configurations:

- **Configuration #1:** Used in a fire rated ceiling that is also the finished ceiling. The damper is installed so there is access to the actuator and closure device through the grille, register, or diffuser.
- **Configuration #2:** Used in a fire rated ceiling that is also the finished ceiling. The damper is installed with access to the actuator and closure device above the finished ceiling. Clearance must be maintained between the damper and grille for proper operation.
- **Configuration #3:** Used where the fire rated ceiling is above the finished ceiling.

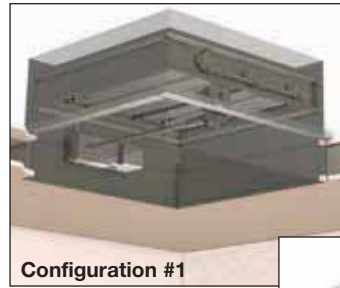

Configuration #1

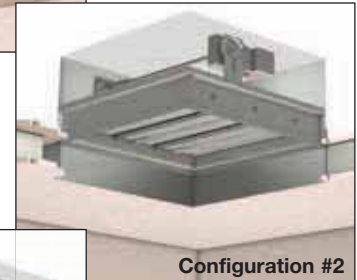

Configuration #2



Configuration #3

Out of Wall Fire Smoke Dampers

Greenheck has tested and qualified combination fire smoke dampers for installations where dampers are installed out of the plane of the fire rated wall. This damper series meets all the requirements of UL 555 and UL 555S for use in walls, partitions, and floors with a fire resistance rating less than 3 hours.

The Out of Wall damper series allows easy access through the grille to the damper, closure device, and the actuator. The damper/sleeve assembly is wrapped in a thermal blanket.

- OFSD Series: 3V or airfoil blade style.
- GFSD Series: 3V blade style. A separate compartment on the side of the damper houses the actuator for installations with limited depth.



OFSD Series



GFSD Series

Vertical Blade

Vertical blade dampers (shown) allow the installer to mount the actuator externally on the top or bottom of the damper when obstructions prevent installation with the actuator mounted on the sides. The FSD-311V has a Class I leakage rating and 350°F (177°C) temperature rating.



FSD-311V

Construction

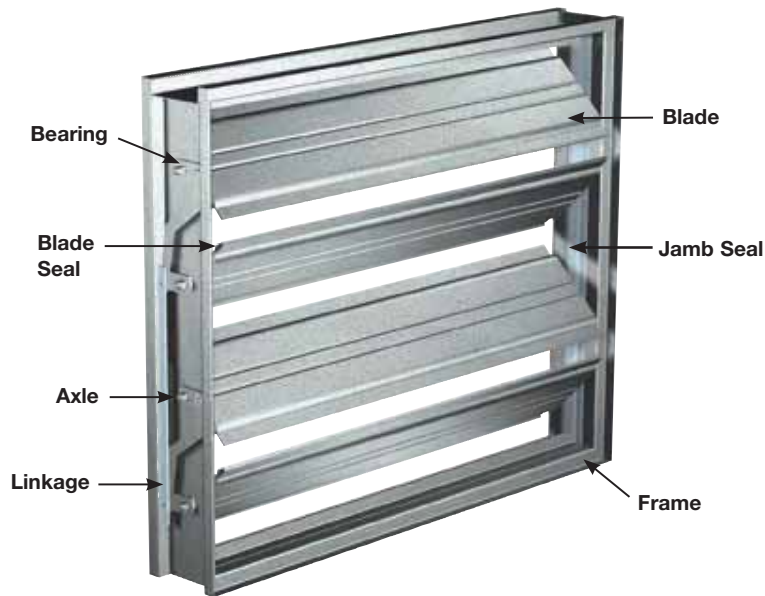

Frame - Tog-L-Loc® Advantage

Greenheck combination fire smoke dampers utilize a 5 in. x 1 in. (127mm x 25mm) hat channel frame. Each frame is built with four separate pieces of material and joined by our Tog-L-Loc® process. The Tog-L-Loc® process provides a more rigid frame that resists “racking” better than welded construction.



Tog-L-Loc®
Reinforced Corner

Maximize Performance - Low Profile Frame

On dampers that are 17 in. (432mm) high or less, Greenheck uses a low profile top and bottom frame to maximize free area which allows for lower pressure drop and increased damper performance.

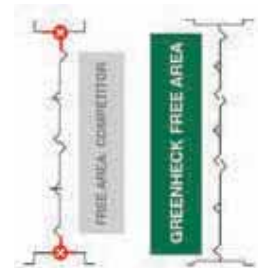

Blades



3V Blade

- Fabricated from a single thickness galvanized steel or stainless steel
- Three V-type grooves running the full length of the blade to increase strength
- Low to medium velocity and pressure applications



Steel Airfoil Blade

- Constructed of double-skin galvanized steel
- This blade design results in lower resistance to airflow and increased strength
- High velocity and pressure applications

Variable Symmetric Blade Design (VSB) - a Greenheck Exclusive!

- Blades are symmetric about their axis
- Combination of 4, 5, 6, and 7 in. (102, 127, 152, and 178mm) blade widths are used in a single damper
- Reduces the need for closure strips which optimize pressure drop performances
- Damper is bi-directional airflow rated
- Through extensive testing of our dampers, we have determined using various blade sizes reduces required actuator torque which reduces the size and quantity of actuators used on dampers. This reduces first costs for the building owner and on-going electrical power consumption.

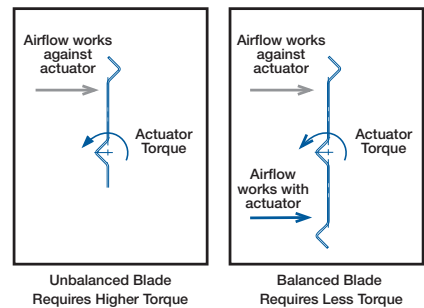

Seals

Seals are used for low leakage applications.

- **Blade seals:** Silicone
- **Jamb seals:** Jamb seals are constructed of flexible 304SS compression type material to help reduce leakage along the blade edges.

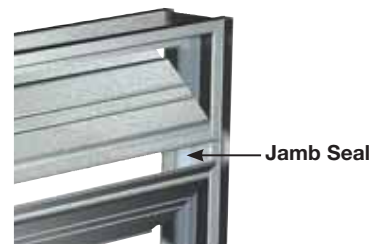

Linkage

Greenheck's combination fire smoke dampers have blade linkages concealed in the frame to prevent additional pressure drop and unwanted noise. The linkage is engineered to accurately control each and every blade without need for adjustment.



Bearings

- 304SS - Standard
- 316SS - Used on SEFSD series

Actuators

A variety of electric and pneumatic actuators are available for all damper models. Each actuator-damper combination is UL Classified to operate up to specific maximum velocities and pressures, with ratings as high as 4000 ft/min. (20 m/s) and 8 in. wg (2 kPa). Actuators can be mounted internally or externally.

Under UL 555 and UL 555S testing, the damper and its installed actuator must be tested as an assembly. Actuators must be furnished factory-installed by the damper manufacturer. Modulating actuators are available for variable volume applications.

See Smoke Damper section for more information.

Actuator Mounting

Actuators must be factory mounted. Factory mounting options may be external on a damper sleeve or sideplate, or mounted internal. Internal actuator mounting (where the actuator is mounted in the airstream) should be avoided if possible, as it increases pressure drop and the difficulty of actuator inspecting, testing, and servicing.

Factory Mounting - External on a Sleeve

As all combination fire smoke dampers require a sleeve for proper installation, the most practical choice is for the damper to be furnished by the factory complete with a sleeve and the actuator installed on the outside of the sleeve. This is the standard and recommended actuator mounting option for combination fire smoke dampers.



Damper mounted in sleeve with actuator externally mounted.

Factory Mounting - Internal

Most actuators can be mounted internally (in the airstream) to accommodate those installations where space constraints prevent the more desirable external installation. There are limitations on small sizes with options (such as the RRL/OCI, OCI, PRV or TOR), which occupy much of the available internal space.



Damper mounted in sleeve with actuator internally mounted.

Closure Devices

UL 555 requires closure devices to have a minimum temperature rating of 160°F (71°C). The maximum temperature rating is 212°F (100°C) for static rated dampers and 350°F (177°C) for dynamic rated dampers. In addition, the IBC states “The operating temperature shall be approximately 50°F (10°C) above the normal temperature within the duct system”.

Resettable Link (RRL) - The RRL replaces the fusible link with a bi-metal heat responsive device that is easily reset from outside the duct (on units with externally mounted actuators). Bi-metal heat responsive devices cut power to the damper spring return actuator when the temperature setpoint is reached. This ensures controlled closure of the damper, eliminating the possibility of duct damage resulting from sudden instantaneous type closures. RRL options are available with temperature ratings of 165°F (74°C), 212°F (100°C), 250°F (121°C) and 350°F (177°C).



RRL

Resettable Link with Open Closed Indicator (RRL/OCI) - The RRL/OCI combines the resettable link (RRL) and the open close indicator (OCI) into one device. RRL/OCI option is available with temperature ratings of 165°F (74°C), 212°F (100°C), 250°F (121°C) and 350°F (177°C).



RRL/OCI

Pneumatic Relief Valve (PRV) - The PRV is a heat responsive device that activates when temperatures in excess of 165°F (74°C) or 212°F (100°C) are detected. When the fusible link melts, air from the actuator is exhausted to close the damper. No electrical connection is required. The PRV must be installed at the factory and cannot be added in the field. An alternative to the PRV is a RRL with EP switch which requires an electrical connection.



PRV

Temperature Override Control (TOR) - The TOR option provides damper closure, usually at 165°F (74°C), with the ability to override this closure (reopen damper) so the duct system can accomplish its intended smoke control system functions as long as the temperature at the damper does not exceed the secondary heat responsive device setting, usually 350°F (177°C).



TOR

Electro-Pneumatic Switch (EP) - This is also known as a three-way solenoid valve and is used to electronically open and close a pneumatic actuated damper. It is wired in series with a normally closed thermostat when used with a fire smoke damper to initiate closure at elevated temperatures. It can also be used on a smoke damper to initiate closure when required in a smoke control system.



EP Switch

Quick Reference Guide

Fire Smoke Dampers

| | Frame | | | | | Blade Profile | | Leakage Class | | | Fire Rating | | | Closure Temperature | | | | | Closure Device | | | Accessories | | | | | | | |
|-----------|---|---------------------|---------------------|----------|---|---------------|---------------|------------------|---------|----------|-------------|--------|------------|---------------------|--------------|---------------|---------------|---------------|----------------|--------------|----------------------------------|--------------------------------------|--------------------------------|------------------|----------------|--------------------|-------------------------------|-------------|-----------------------------|
| | 5 x 1 in. x 16 ga. Galvanized Steel Hat Channel | 304 Stainless Steel | 316 Stainless Steel | Aluminum | 8 x 2 in. x 12 ga. Galvanized Steel Hat Channel | 3V | Steel Airfoil | Aluminum Airfoil | Class I | Class II | Class III | 1 Hour | 1 1/2 Hour | 3 Hour | 165°F (74°C) | 212°F (100°C) | 250°F (121°C) | 286°F (141°C) | 350°F (177°C) | Fusible Link | 1 Reusable Resettable Link (RRL) | 2 Temperature Limited Override (TOR) | 3 Pneumatic Relief Valve (PRV) | Retaining Angles | Smoke Detector | Momentary Switches | Open or Close Indicator (OCI) | Transformer | Greenheck Test Switch (GTS) |
| CFSD-211 | X | | | | | X | | X | | | X | | | X | O | O | O | O | O | X | O | O | O | O | O | O | O | O | O |
| CFSD-212 | X | | | | | X | | | X | | X | | | X | O | O | O | O | O | X | O | O | O | O | O | O | O | O | O |
| FSD-211 | X | | | | | X | | X | | | X | | | X | O | O | O | O | O | X | O | O | O | O | O | O | O | O | O |
| FSD-212 | X | | | | | X | | | X | | X | | | X | O | O | O | O | O | X | O | O | O | O | O | O | O | O | O |
| FSD-213 | X | | | | | X | | | | X | X | | | X | O | O | O | O | O | X | O | O | O | O | O | O | O | O | O |
| SEFSD-211 | | X | | | | X | | X | | | X | | | X | O | O | O | O | O | X | O | O | O | O | O | O | O | O | O |
| SSFSD-211 | | X | | | | X | | X | | | X | | | X | O | O | O | O | O | X | O | O | O | O | O | O | O | O | O |
| FSD-311 | X | | | | | | X | X | | | X | | | X | O | O | O | O | O | X | O | O | O | O | O | O | O | O | O |
| FSD-312 | X | | | | | | X | | X | | X | | | X | O | O | O | O | O | X | O | O | O | O | O | O | O | O | O |
| FSD-311M | X | | | | | | X | X | | | X | | | X | O | O | | | | X | O | | O | O | O | O | O | O | O |
| FSD-312M | X | | | | | | X | | X | | X | | | X | O | O | | | | X | O | | O | O | O | O | O | O | O |
| FSD-311V | X | | | | | | X | X | | | X | | | X | O | O | | O | | X | O | O | O | O | O | O | O | O | O |
| FSD-331 | X | | | | | | X | X | | | | X | | X | O | O | O | O | O | X | O | O | O | O | O | O | O | O | O |
| GFSD-211 | X | | | | | X | | X | | | X | | | X | O | O | O | O | O | X | O | O | O | O | O | O | O | O | O |
| GFSD-212 | X | | | | | X | | | X | | X | | | X | O | O | O | O | O | X | O | O | O | O | O | O | O | O | O |
| OFSD-211 | X | | | | | X | | X | | | X | | | X | O | O | O | O | O | X | O | O | O | O | O | O | O | O | O |
| OFSD-212 | X | | | | | X | | | X | | X | | | X | O | O | O | O | O | X | O | O | O | O | O | O | O | O | O |
| OFSD-311 | X | | | | | | X | X | | | X | | | X | O | O | O | O | O | X | O | O | O | O | O | O | O | O | O |
| OFSD-312 | X | | | | | | X | | X | | X | | | X | O | O | O | O | O | X | O | O | O | O | O | O | O | O | O |

¹ Available with or without Open or Closed Indicator; EP switch required if pneumatic actuator is used.

² Includes Open or Closed Indicator; EP switch required if pneumatic actuator used.

³ For use with pneumatic actuators.

Maximum Damper Size Limitations

| Model | Leakage Class | Size Limitations - W x H, in inches (mm) | | | | | | Maximum | | | | |
|----------------------|-------------------------------|--|------------------------|--|-------------------------|--|---------------------------|--------------------------------|------------------------------|-----------------------------|----------------|----------------|
| | | Single Section | | | | Multi-section | | Temperature Ratings °F (°C) | Velocity ft/min. (m/s) | Pressure in. wg (kPa) | | |
| | | Horizontal | | Vertical | | Horizontal | Vertical | | | | | |
| | | Minimum | Maximum | Minimum | Maximum | Maximum | | | | | | |
| 1 ½ Hour | FSD-211 FSD-212 FSD-213 | I II III | 8 x 6 (203 x 152) | 32 x 50 or 36 x 48 (813 x 1270 or 914 x 1219) | 8 x 6 (203 x 152) | 32 x 50 or 36 x 48 (813 x 1270 or 914 x 1219) | 144 x 96 (3658 x 2438) | 128 x 100 (3251 x 2540) | 350° (177°) | 2000 (10.2) | 4 (1) | |
| | 36 x 48 (914 x 1219) | | | 36 x 48 (914 x 1219) | | 144 x 48 (3658 x 1219) | 128 x 48 (3251 x 1219) | 6 (1.5) | | | | |
| | FSD-211M | I | 8 x 6 (203 x 152) | 36 x 36 (914 x 914) | 8 x 6 (203 x 152) | 36 x 36 (914 x 914) | 36 x 72 (914 x 1829) | 36 x 72 (914 x 1829) | 250° (121°) | 2000 (10.2) | 4 (1) | |
| | SSFSD-211 SEFSD-211 | I | 8 x 6 (203 x 152) | 24 x 30 (610 x 762) | 8 x 6 (203 x 152) | 24 x 30 or 22 x 36 (610 x 762 or 559 x 914) | 48 x 30 (1219 x 762) | 88 x 72 (2235 x 1829) | 350° (177°) | 2000 (10.2) | 4 (1) | |
| | | | | | | 24 x 30 (610 x 762) | 48 x 30 (1219 x 762) | 88 x 48 (2235 x 1219) | | | 6 (1.5) | |
| | GFSD-211 GFSD-212 | I II | 14 x 12 (356 x 305) | 42 x 48 (1067 x 1219) | 14 x 12 (356 x 305) | 42 x 48 (1067 x 1219) | 48 x 48 (1219 x 1219) | 48 x 48 (1219 x 1219) | 350° (177°) | 2000 (10.2) | 4 (1) | |
| | FSD-311 FSD-312 | I II | 8 x 6 (203 x 152) | 32 x 50 (813 x 1270) | 8 x 6 (203 x 152) | 32 x 50 (813 x 1270) | 144 x 96 (3658 x 2438) | 128 x 100 (3251 x 2540) | 350° (177°) | 2000 (10.2) | 8 (2) | |
| | | | | | | | 128 x 96 (3251 x 2438) | 128 x 100 (3251 x 2540) | | | 3000 (15.2) | 8 (2) |
| | | | | | | | 128 x 96 (3251 x 2438) | 128 x 50 (3251 x 1270) | | | 350° (177°) | 4000 (20.3) |
| | FSD-311M FSD-312M | I II | 8 x 6 (203 x 152) | 32 x 50 (813 x 1270) | 8 x 6 (203 x 152) | 32 x 50 (813 x 1270) | 128 x 96 (3251 x 2438) | 128 x 100 (3251 x 2540) | 250° (121°) | 2000 (10.2) | 4 (1) | |
| FSD-311V | I | -- | -- | 6 x 8 (152 x 203) | 50 x 32 (1270 x 813) | -- | 100 x 32 (2540 x 813) | 350° (177°) | 2000 (10.2) | 4 (1) | | |
| | | -- | -- | 6 x 8 (152 x 203) | 50 x 32 (1270 x 813) | -- | -- | 350° (177°) | 4000 (20.3) | 4 (1) | | |
| CFSD-211 CFSD-212 | I II | 8 x 6 (203 x 152) | 24 x 24 (610 x 610) | 8 x 6 (203 x 152) | 24 x 24 (610 x 610) | -- | | 350° (177°) | 2000 (10.2) | 6 (1.5) | | |
| OFSD-211 OFSD-212 | I II | 12 x 12 (305 x 305) | 36 x 36 (914 x 914) | 12 x 12 (305 x 305) | 36 x 36 (914 x 914) | -- | | 350° (177°) | 2000 (10.2) | 6 (1.5) | | |
| OFSD-311 OFSD-312 | I II | 12 x 12 (305 x 305) | 32 x 30 (813 x 762) | 12 x 12 (305 x 305) | 32 x 30 (813 x 762) | 36 x 36 (914 x 914) | 36 x 36 (914 x 914) | 350° (177°) | 4000 (20.3) | 4 (1) | | |
| 3 Hour | FSD-331 | I | -- | -- | 8 x 6 (203 x 152) | 32 x 36 or 30 x 48 (813 x 914 or 762 x 1219) | 144 x 96 (3658 x 2438) | 120 x 96 (3048 x 2438) | 350° (177°) | 3000 (15.2) | 8 (2) | |
| | | | | | | 120 x 96 (3048 x 2438) | 120 x 96 (3048 x 2438) | 350° (177°) | 4000 (20.3) | 4 (1) | | |

Fire Smoke
Dampers



CFSD Series



GFSD Series



OFSD Series

Round Dampers

Application

UL (Underwriters Laboratories) Classified round fire, smoke, and combination fire smoke dampers are used in applications with round ductwork.

Mounting

Round fire, smoke, and combination fire smoke dampers are available for mounting either vertically or horizontally. All round life safety dampers feature an integral sleeve for easy connection to adjoining ductwork.



Model FDR-510

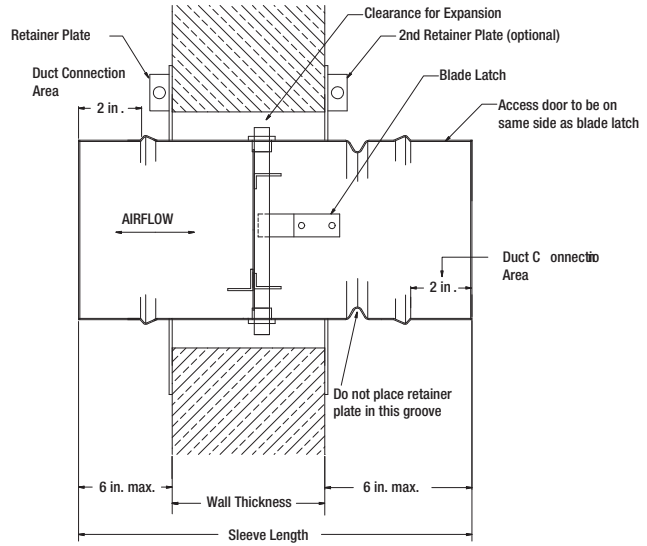

Blade Orientation

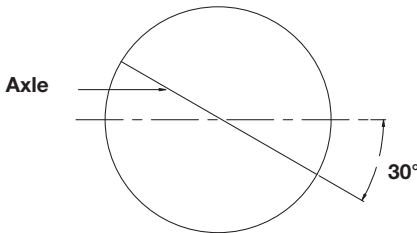

30° Off Horizontal (Maximum)

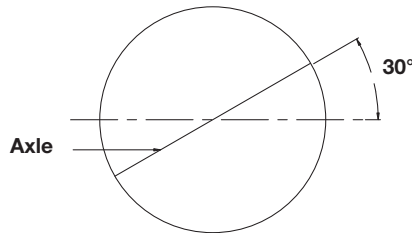

30° Off Horizontal (Maximum)

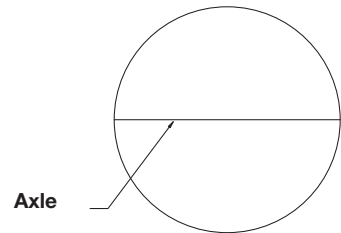

Normal

Retaining Plates

Square one-piece retaining plates easily wrap around the sleeve of the damper and tighten with the clamping screw for simplified installation. They are designed to mount flush to the wall/floor and hold the damper in the opening. One retaining plate is provided standard with each round fire and combination fire smoke damper.

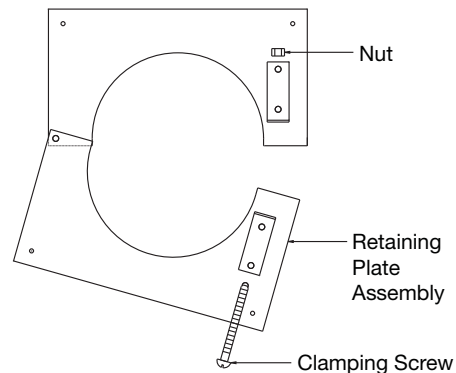

Quick Reference Guide

| X = Standard O = Optional | | DFDR-510 | FDR-510 | FSDR-511 | FSDR-512 | SEFSDR-511 | SESMDR-501 | SMDR-501 | SMDR-502 | SSDFDR-510 | SSFDR-510 | SSFSDR-511 | SSSMDR-501 |
|------------------------------|-----------------------------|-------------|-------------|-------------|-------------|-------------|-------------|-------------|-------------|-------------|-------------|-------------|-------------|
| Damper Type | Static Fire | - | X | - | - | - | - | - | - | - | X | - | - |
| | Dynamic Fire | X | - | - | - | - | - | - | - | X | - | - | - |
| | Combination Fire Smoke | - | - | X | X | X | - | - | - | - | - | X | - |
| | Smoke | - | - | - | - | - | X | X | X | - | - | - | X |
| UL Listing | UL 555 1½ hour Fire Rating | X | X | X | X | X | - | - | - | X | X | X | - |
| | UL 555S Class I Leakage | - | - | X | - | X | X | X | - | - | - | X | X |
| | UL 555S Class II Leakage | - | - | - | X | - | - | - | X | - | - | - | - |
| Material | Galvanized Steel | X | X | X | X | - | - | X | X | - | - | - | - |
| | 304 Stainless Steel | - | - | - | - | - | - | - | - | X | X | X | X |
| | 316SS Stainless Steel | - | - | - | - | X | X | - | - | - | - | - | - |
| Closure Device | Fusible Link | X | X | X | X | X | - | - | - | X | X | X | - |
| | RRL | - | - | O | O | O | - | - | - | - | - | O | - |
| | RRL/OCI | - | - | O | O | O | - | - | - | - | - | O | - |
| | TOR | - | - | O | O | O | - | - | - | - | - | O | - |
| | PRV | - | - | O | O | O | - | - | - | - | - | O | - |
| Closure Temperature | 165°F (74°C) | X | X | X | X | X | - | - | - | X | X | X | - |
| | 212°F (100°C) | O | O | O | O | O | - | - | - | O | O | O | - |
| | 250° (121°C) | - | - | O | O | O | - | - | - | - | - | O | - |
| | 286°F (148°C) | O | O | O | O | O | - | - | - | O | O | O | - |
| | 350°F (177°C) | - | - | O | O | O | - | - | - | - | - | O | - |
| Mounting | Horizontal | X | X | X | X | X | X | X | X | X | X | X | X |
| | Vertical | X | X | X | X | X | X | X | X | X | X | X | X |
| Accessories | Retaining Plates | X | X | X | X | X | - | - | - | X | X | X | - |
| | Momentary Test Switch | - | - | O | O | O | O | O | O | - | - | O | O |
| | Transformer | - | - | O | O | O | O | O | O | - | - | O | O |
| | Greenheck Test Switch (GTS) | - | - | O | O | O | O | O | O | - | - | O | O |
| | Smoke Detector | - | - | O | O | - | - | O | O | - | - | O | O |
| | Open Close Indicator (OCI) | - | - | O | O | O | - | O | O | - | - | O | O |
| Maximum | Diameter in. (mm) | 24 (610) | 24 (610) | 24 (610) | 24 (610) | 24 (610) | 24 (610) | 24 (610) | 24 (610) | 24 (610) | 24 (610) | 24 (610) | 24 (610) |
| | Velocity fpm (m/s) | 2000 (10.2) | - | 3000 (15.2) | 3000 (15.2) | 3000 (15.2) | 3000 (15.2) | 3000 (15.2) | 3000 (15.2) | - | 2000 (10.2) | 3000 (15.2) | 3000 (15.2) |
| | Pressure in. wg (kPa) | 4 (1) | - | 4 (1) | 4 (1) | 4 (1) | 4 (1) | 4 (1) | 4 (1) | - | 4 (1) | 4 (1) | 4 (1) |
| | Temperature °F (°C) | 286° (141°) | 286° (141°) | 350° (177°) | 350° (177°) | 350° (177°) | 350° (177°) | 350° (177°) | 350° (177°) | 350° (177°) | 286° (141°) | 286° (141°) | 350° (177°) |

Round
Dampers

Ceiling Radiation Dampers

Application

Ceiling radiation dampers (also called ceiling dampers) are designed to protect openings in the ceiling membrane of rated floor/ceiling and roof/ceiling assemblies. Ceiling radiation dampers close upon the activation of a temperature response device designed to release at a selected temperature (this is usually a 165°F (74°C) fusible link*).

The UL Fire Resistance Directory contains the design specifications of hundreds of different fire rated building elements. The first step in determining the appropriate ceiling damper for a given application should be to review its listed design in the UL Fire Resistance Directory (or equivalent directory). Not all floor/ceiling and roof/ceiling designs allow dampers to be installed.

Non-Combustible

Non-combustible assemblies are floor/ceiling and roof/ceiling designs that do not use wood as their structural members. Many non-combustible assemblies require the use of acoustical ceiling tiles as a protective ceiling membrane for the structural members. Assemblies that were fire tested with what are known as “hinged door type dampers” protecting HVAC penetrations through the ceiling membrane may utilize any UL 555C listed ceiling radiation damper. Floor/ceiling and roof/ceiling assemblies that allow the use of UL 555C listed dampers can be identified by reviewing the construction features of the design in the UL Fire Resistance Directory. If the design calls out dampers as an allowable component and describes the required damper construction, as opposed to calling out specific damper models and manufacturers, then UL 555C listed dampers may be used.

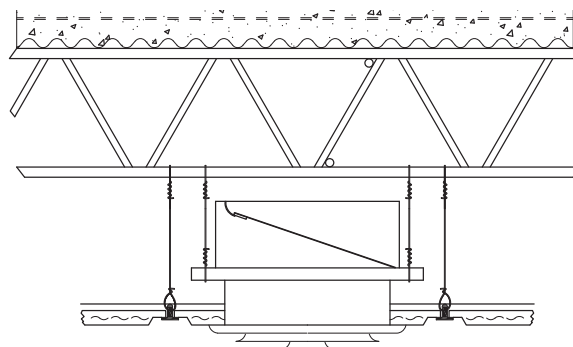

Typical non-combustible floor/ceiling assembly that utilizes an UL 555C damper

Greenheck's UL 555C listed dampers are approved for use in floor/ceiling and roof/ceiling assemblies with fire resistance ratings of three hours or less.



CRD-1 butterfly



CRD-1LP low profile butterfly



CRD-2 round butterfly



CRD-60 curtain blade style



CRD-60 curtain blade style with skirt

*The IBC states that the closure temperature shall be approximately 50°F above the normal temperature within the duct system.

Ceiling Radiation Dampers

Combustible

Rated floor/ceiling and roof/ceiling assemblies that utilize wood trusses or wood joists as their structural membrane are often referred to as “Combustible Assemblies”. Because their structural members are combustible, most of these assemblies require the use of a gypsum board ceiling membrane. Combustible assemblies that were tested with HVAC penetrations in their ceiling membrane require the use of better insulated dampers. Dampers that only carry a UL 555C listing are not approved for these applications. Combustible designs in the UL Fire Resistance Directory that were tested with a damper, call out the specific damper manufacturer and models that are approved to be used. Because the tests for many of these designs were sponsored by a damper manufacturer, the approved damper models in a given design number may be limited to a single manufacturer. However, other damper manufacturer’s damper models are often approved to be used in different design numbers that permit the same construction material and methods.



Typical floor/ceiling assembly with wood joist
CRD-1WJ shown

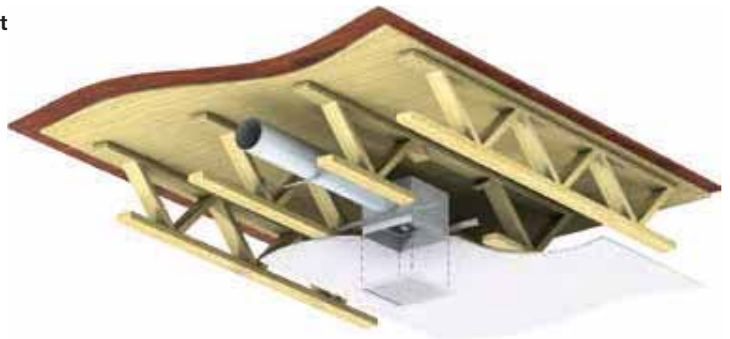

Typical floor/ceiling assembly with wood truss
CRD-1WT shown

Low Leakage Ceiling Radiation Damper

The CRD-501 is a round ceiling radiation damper with a Class I Smoke Leakage Rating. It is UL Classified as a ceiling radiation (UL 555C) and as a smoke damper (UL 555S). As a UL 555C ceiling radiation damper, it is used in floor/ceiling and roof/ceiling assemblies to maintain the fire resistance integrity of the assembly during fire exposure. As a UL 555S smoke damper, model CRD-501 is a Class I smoke leakage rated damper designed to control the spread of smoke.



CRD-501

Ceiling Radiation Dampers

Options

Frame Extensions

Top, bottom, or both top and bottom frame extensions are available on CRD-1, CRD-1LP, and CRD-2.

Mounting

Grille mount or duct mount for the CRD-1WT.

Plenum

The CRD-1WT dampers must have a plenum installed per UL. We can offer steel plenum, ductboard plenum, or they can choose to do a customer supplied plenum.

Thermal Blankets

Greenheck offers two different types of thermal blankets with ceiling radiation dampers to be used as batt and blanket material. QB-24 is a refractory thermal blanket consisting of a non-asbestos high temperature ceramic fiber blanket quilted between two layers of fiberglass cloth. The TB-24 is a non-asbestos mineral wool thermal blanket.

Volume Controller

A volume controller gives you the ability to regulate airflow through the damper by manually setting the blades to a given angle. Adjusting the screw will open or close the blades. Available on all CRD models.

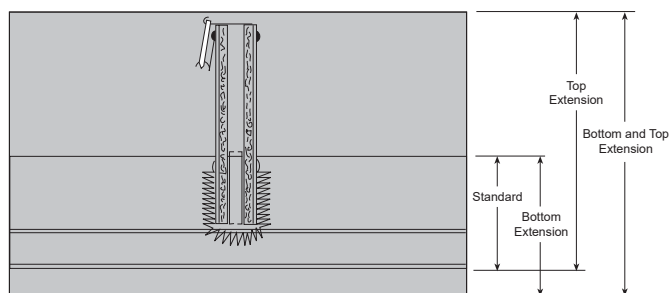

Frame Extensions

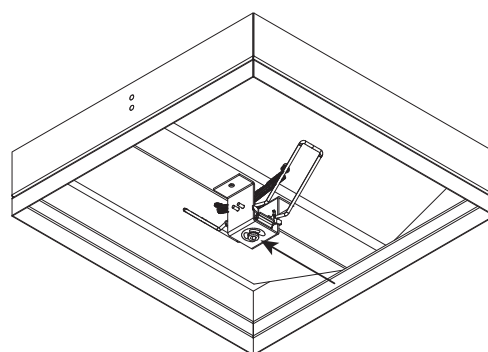

Volume Controller

Ceiling Radiation Dampers - Models and Sizes

| Model | Butterfly Style | | | | | Curtain Style | | Round | |
|--------------------------|------------------------|------------------------|------------------------|------------------------|------------------------|------------------------|------------------------|-------------|-------------|
| | CRD-1 | CRD-1LP Low Profile | CRD-1WJ | CRD-1WT | CRD-2WT | CRD-60 | CRD-60X | CRD-2 | CRD-501 |
| Minimum Size in. (mm) | 4 x 6 (102 x 152) | 4 x 12 (102 x 305) | 4 x 6 (102 x 152) | 4 x 6 (102 x 152) | 5 x 5 (127 x 127) | 6 x 4 (152 x 102) | 6 x 4 (152 x 102) | 5 (127) | 6 (152) |
| Maximum Size in. (mm) | 24 x 24 (610 x 610) | 24 x 24 (610 x 610) | 16 x 12 (406 x 305) | 21 x 18 (533 x 457) | 12 x 12 (305 x 305) | 24 x 24 (610 x 610) | 24 x 24 (610 x 610) | 24 (610) | 12 (305) |

Performance Data

Pressure drop testing was conducted in accordance with AMCA Standard 500-D using the three configurations shown. All data has been corrected to represent standard air at a density of .075 lb/ft³ (1.2 kg/m³).

Actual pressure drop found in a HVAC system is a combination of many factors. This pressure drop information, along with an analysis of other system influences should be used to estimate actual pressure losses for a damper installed in an HVAC system.

Figure 5.3 Illustrates a fully ducted damper. This configuration has the lowest pressure drop of the three test configurations because entrance and exit losses are minimized by straight duct runs upstream and downstream of the damper.

Figure 5.2 Illustrates a ducted damper exhausting air into an open area. This configuration has a lower pressure drop than Figure 5.5 because entrance losses are minimized by a straight duct run upstream of the damper.

Figure 5.5 Illustrates a plenum mounted damper. This configuration has the highest pressure drop because of high entrance and exit losses due to the sudden changes of area in the system.

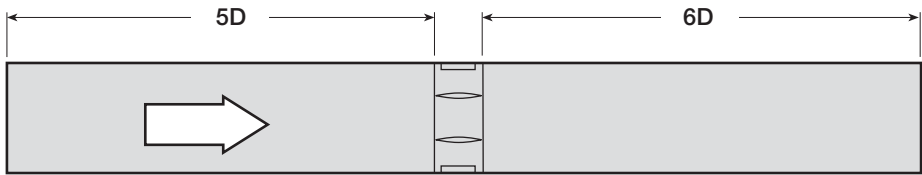

Figure 5.3

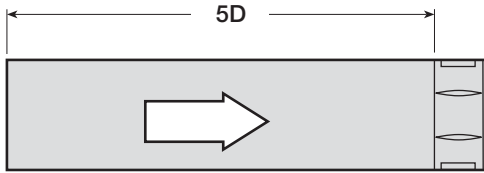

Figure 5.2

D = Duct length
 W = Damper width
 H = Damper height

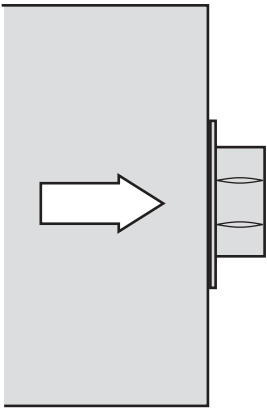



Figure 5.5

$$D = \sqrt{\frac{4(W)(H)}{3.14}}$$



Greenheck Fan Corporation certifies that the models CFSD-211, 212; DFD-210; DFDAF-310, 330; SEDFD-210; FSD-211, 211M, 212, 213, 311, 311M, 312, 312M, 331; SSFSD-211; SEFSD-211; OFSD-211, 212, 311, 312; SMD-201, 201M, 202, 203, 301, 301M, 302, 302M, 401EF; SESMD-201 and SSSMD-201 shown herein are licensed to bear the AMCA Seal. The ratings shown are based on tests and procedures performed in accordance with AMCA Publication 511 and comply with the requirements of the AMCA Certified Ratings Programs. The AMCA Certified Ratings Seal applies to air performance only.



Greenheck India Pvt. Ltd. certifies that the models DFD-210; DFDAF-310, 330; FSD-211, 212, 311, 312, 331; SMD-201, 202, 301 and 302 shown herein are licensed to bear the AMCA Seal. The ratings shown are based on tests and procedures performed in accordance with AMCA Publication 511 and comply with the requirements of the AMCA Certified Ratings Programs. The AMCA Certified Ratings Seal applies to air performance only.

Pressure Drop

These pressure drop charts apply to the following models: CFSD-211, 212; DFD-210; SEDFD-210; FSD-211, 211M, 212, 213; OFSD-211, 212; SEFSD-211; SSFSD-211; SMD-201, 201M, 202, 203; SESMD-201; and SSSMD-201.

AMCA Figure 5.2 Pressure Drop

| Dimension in. (mm) | 12 x 12 (305 x 305) | 24 x 24 (610 x 610) | 36 x 36 (914 x 914) | 12 x 48 (305 x 1219) | 48 x 12 (1219 x 305) |
|--------------------|------------------------|------------------------|------------------------|-------------------------|-------------------------|
| Velocity (ft/min.) | Pressure Drop - in. wg | | | | |
| 500 | .04 | .02 | .01 | .01 | .03 |
| 1000 | .14 | .07 | .04 | .06 | .10 |
| 1500 | .32 | .16 | .09 | .13 | .23 |
| 2000 | .56 | .29 | .16 | .23 | .41 |
| 2500 | .86 | .45 | .25 | .36 | .63 |
| 3000 | 1.24 | .65 | .36 | .52 | .91 |
| 3500 | 1.69 | .89 | .49 | .70 | 1.24 |
| 4000 | 2.20 | 1.16 | .64 | .92 | 1.62 |

AMCA Figure 5.3 Pressure Drop

| Dimension in. (mm) | 12 x 12 (305 x 305) | 24 x 24 (610 x 610) | 36 x 36 (914 x 914) | 12 x 48 (305 x 1219) | 48 x 12 (1219 x 305) |
|--------------------|------------------------|------------------------|------------------------|-------------------------|-------------------------|
| Velocity (ft/min.) | Pressure Drop - in. wg | | | | |
| 500 | .02 | .01 | .01 | .01 | .02 |
| 1000 | .09 | .04 | .03 | .04 | .07 |
| 1500 | .20 | .09 | .06 | .10 | .16 |
| 2000 | .36 | .16 | .11 | .17 | .29 |
| 2500 | .56 | .25 | .17 | .27 | .45 |
| 3000 | .81 | .35 | .24 | .39 | .64 |
| 3500 | 1.10 | .48 | .33 | .53 | .88 |
| 4000 | 1.44 | .63 | .42 | .70 | 1.14 |

AMCA Figure 5.5 Pressure Drop

| Dimension in. (mm) | 12 x 12 (305 x 305) | 24 x 24 (610 x 610) | 36 x 36 (914 x 914) | 12 x 48 (305 x 1219) | 48 x 12 (1219 x 305) |
|--------------------|------------------------|------------------------|------------------------|-------------------------|-------------------------|
| Velocity (ft/min.) | Pressure Drop - in. wg | | | | |
| 500 | .06 | .03 | .03 | .03 | .04 |
| 1000 | .22 | .14 | .12 | .13 | .17 |
| 1500 | .50 | .31 | .26 | .30 | .38 |
| 2000 | .89 | .54 | .46 | .53 | .67 |
| 2500 | 1.39 | .85 | .73 | .83 | 1.04 |
| 3000 | 2.00 | 1.22 | 1.05 | 1.19 | 1.50 |
| 3500 | 2.72 | 1.66 | 1.42 | 1.62 | 2.05 |
| 4000 | 3.55 | 2.17 | 1.86 | 2.11 | 2.67 |

Pressure Drop

These pressure drop charts apply to the following models: DFDAF-310, 330; FSD-311, 311M; FSD-312, 312M; FSD-331; OFSD-311, 312; SMD-301, 302; SMD-301M and 302M.

AMCA Figure 5.2 Pressure Drop

| Dimension in. (mm) | 12 x 12 (305 x 305) | 24 x 24 (610 x 610) | 36 x 36 (914 x 914) | 12 x 48 (305 x 1219) | 48 x 12 (1219 x 305) |
|--------------------|------------------------|------------------------|------------------------|-------------------------|-------------------------|
| Velocity (ft/min.) | Pressure Drop - in. wg | | | | |
| 500 | .03 | .01 | .01 | .01 | .02 |
| 1000 | .11 | .06 | .05 | .05 | .08 |
| 1500 | .24 | .12 | .12 | .12 | .18 |
| 2000 | .42 | .22 | .21 | .21 | .33 |
| 2500 | .66 | .34 | .32 | .33 | .51 |
| 3000 | .95 | .49 | .47 | .48 | .74 |
| 3500 | 1.30 | .67 | .63 | .65 | 1.00 |
| 4000 | 1.70 | .87 | .83 | .85 | 1.31 |

AMCA Figure 5.3 Pressure Drop

| Dimension in. (mm) | 12 x 12 (305 x 305) | 24 x 24 (610 x 610) | 36 x 36 (914 x 914) | 12 x 48 (305 x 1219) | 48 x 12 (1219 x 305) |
|--------------------|------------------------|------------------------|------------------------|-------------------------|-------------------------|
| Velocity (ft/min.) | Pressure Drop - in. wg | | | | |
| 500 | .01 | .01 | .01 | .01 | .01 |
| 1000 | .06 | .02 | .02 | .03 | .04 |
| 1500 | .13 | .06 | .05 | .06 | .10 |
| 2000 | .23 | .10 | .09 | .11 | .18 |
| 2500 | .36 | .16 | .14 | .18 | .29 |
| 3000 | .53 | .23 | .21 | .25 | .42 |
| 3500 | .73 | .32 | .29 | .34 | .57 |
| 4000 | .95 | .42 | .38 | .45 | .74 |

AMCA Figure 5.5 Pressure Drop

| Dimension in. (mm) | 12 x 12 (305 x 305) | 24 x 24 (610 x 610) | 36 x 36 (914 x 914) | 12 x 48 (305 x 1219) | 48 x 12 (1219 x 305) |
|--------------------|------------------------|------------------------|------------------------|-------------------------|-------------------------|
| Velocity (ft/min.) | Pressure Drop - in. wg | | | | |
| 500 | .04 | .03 | .03 | .03 | .03 |
| 1000 | .18 | .13 | .12 | .12 | .14 |
| 1500 | .42 | .29 | .27 | .27 | .32 |
| 2000 | .75 | .52 | .48 | .49 | .57 |
| 2500 | 1.17 | .81 | .75 | .77 | .89 |
| 3000 | 1.68 | 1.17 | 1.08 | 1.11 | 1.28 |
| 3500 | 2.29 | 1.60 | 1.48 | 1.51 | 1.75 |
| 4000 | 2.09 | 2.14 | 1.93 | 1.97 | 2.29 |

Pressure Drop

These pressure drop charts apply to the following models: SMD-401, SMD-401M, and SMD-401EF.

AMCA Figure 5.2 Pressure Drop

| Dimension in. (mm) | 12 x 12 (305 x 305) | 24 x 24 (610 x 610) | 36 x 36 (914 x 914) | 12 x 48 (305 x 1219) | 48 x 12 (1219 x 305) |
|--------------------|------------------------|------------------------|------------------------|-------------------------|-------------------------|
| Velocity (ft/min.) | Pressure Drop - in. wg | | | | |
| 500 | .01 | .01 | .01 | .01 | .01 |
| 1000 | .06 | .04 | .03 | .06 | .03 |
| 1500 | .13 | .10 | .06 | .13 | .06 |
| 2000 | .23 | .18 | .12 | .23 | .10 |
| 2500 | .35 | .28 | .18 | .36 | .16 |
| 3000 | .50 | .40 | .26 | .51 | .23 |
| 3500 | .68 | .54 | .35 | .71 | .30 |
| 4000 | .88 | .70 | .46 | .93 | .39 |

AMCA Figure 5.3 Pressure Drop

| Dimension in. (mm) | 12 x 12 (305 x 305) | 24 x 24 (610 x 610) | 36 x 36 (914 x 914) | 12 x 48 (305 x 1219) | 48 x 12 (1219 x 305) |
|--------------------|------------------------|------------------------|------------------------|-------------------------|-------------------------|
| Velocity (ft/min.) | Pressure Drop - in. wg | | | | |
| 500 | .01 | .01 | .01 | .01 | .01 |
| 1000 | .03 | .02 | .01 | .03 | .02 |
| 1500 | .07 | .04 | .02 | .06 | .04 |
| 2000 | .14 | .08 | .04 | .11 | .08 |
| 2500 | .21 | .13 | .06 | .17 | .12 |
| 3000 | .29 | .19 | .09 | .25 | .18 |
| 3500 | .39 | .26 | .13 | .34 | .24 |
| 4000 | .51 | .34 | .17 | .45 | .31 |

AMCA Figure 5.5 Pressure Drop

| Dimension in. (mm) | 12 x 12 (305 x 305) | 24 x 24 (610 x 610) | 36 x 36 (914 x 914) | 12 x 48 (305 x 1219) | 48 x 12 (1219 x 305) |
|--------------------|------------------------|------------------------|------------------------|-------------------------|-------------------------|
| Velocity (ft/min.) | Pressure Drop - in. wg | | | | |
| 500 | .04 | .03 | .03 | .03 | .03 |
| 1000 | .14 | .12 | .10 | .11 | .11 |
| 1500 | .31 | .27 | .22 | .25 | .26 |
| 2000 | .55 | .48 | .39 | .46 | .46 |
| 2500 | .86 | .75 | .61 | .72 | .72 |
| 3000 | 1.23 | 1.07 | .87 | 1.05 | 1.02 |
| 3500 | 1.67 | 1.47 | 1.19 | 1.43 | 1.40 |
| 4000 | 2.19 | 1.91 | 1.56 | 1.87 | 1.83 |

Pressure Drop

These pressure drop charts apply to the following models: DFD-110, 150, 310, 350; DFD-150X series; ODFD-150; SSDFD-150 and 350.

AMCA Figure 5.2 Pressure Drop

| Dimension in. (mm) | 12 x 12 (305 x 305) | 24 x 24 (610 x 610) | 36 x 36 (914 x 914) | 12 x 48 (305 x 1219) | 48 x 12 (1219 x 305) |
|--------------------|------------------------|------------------------|------------------------|-------------------------|-------------------------|
| Velocity (ft/min.) | Pressure Drop - in. wg | | | | |
| 500 | .06 | .02 | .016 | .05 | .05 |
| 1000 | .11 | .08 | .06 | .10 | .09 |
| 1500 | .26 | .17 | .15 | .21 | .20 |
| 2000 | .48 | .31 | .26 | .38 | .37 |
| 2500 | .72 | .49 | .41 | .58 | .58 |
| 3000 | 1.02 | .70 | .59 | .83 | .85 |
| 3500 | 1.40 | .94 | .80 | 1.18 | 1.17 |
| 4000 | 1.84 | 1.27 | 1.04 | 1.55 | 1.58 |

AMCA Figure 5.3 Pressure Drop

| Dimension in. (mm) | 12 x 12 (305 x 305) | 24 x 24 (610 x 610) | 36 x 36 (914 x 914) | 12 x 48 (305 x 1219) | 48 x 12 (1219 x 305) |
|--------------------|------------------------|------------------------|------------------------|-------------------------|-------------------------|
| Velocity (ft/min.) | Pressure Drop - in. wg | | | | |
| 500 | .02 | .01 | .005 | .02 | .02 |
| 1000 | .04 | .03 | .02 | .04 | .04 |
| 1500 | .09 | .05 | .04 | .09 | .09 |
| 2000 | .17 | .10 | .07 | .16 | .15 |
| 2500 | .27 | .15 | .11 | .24 | .23 |
| 3000 | .38 | .23 | .16 | .36 | .33 |
| 3500 | .52 | .29 | .21 | .49 | .45 |
| 4000 | .69 | .40 | .28 | .63 | .60 |

AMCA Figure 5.5 Pressure Drop

| Dimension in. (mm) | 12 x 12 (305 x 305) | 24 x 24 (610 x 610) | 36 x 36 (914 x 914) | 12 x 48 (305 x 1219) | 48 x 12 (1219 x 305) |
|--------------------|------------------------|------------------------|------------------------|-------------------------|-------------------------|
| Velocity (ft/min.) | Pressure Drop - in. wg | | | | |
| 500 | .10 | .09 | .07 | .10 | .09 |
| 1000 | .19 | .16 | .14 | .18 | .15 |
| 1500 | .43 | .36 | .34 | .41 | .35 |
| 2000 | .72 | .65 | .60 | .72 | .63 |
| 2500 | 1.18 | .98 | .92 | 1.14 | .97 |
| 3000 | 1.66 | 1.45 | 1.31 | 1.61 | 1.40 |
| 3500 | 2.30 | 1.97 | 1.85 | 2.25 | 1.92 |
| 4000 | 3.30 | 2.64 | 2.37 | 2.95 | 2.54 |

Factory Mounted Accessories

Access Doors

According to NFPA 80 and NFPA 90A, an access door needs to be provided in air ducts adjacent to each fire damper, smoke damper, or combination fire smoke damper for maintenance and inspection.

Let Greenheck install the access door in the sleeve to save on time and labor costs in the field.



Retaining Angle

Save time by letting Greenheck install retaining angles for you. You can order your retaining angles four different ways:

- **Single Fastened** - one retaining angle mounted in the location you want
- **Single Wrapped** - one retaining angle wrapped around the damper sleeve and wire tied
- **Double Wrapped** - the same feature as single wrapped, but with 2 sets of retaining angles
- **Fastened and Wrapped** - one retaining angle fastened and one angle wrapped around the damper



Quick Connect Breakaway Connections

Greenheck was the first manufacturer to successfully UL Qualify a universal breakaway duct connection that is compatible with TDC, TDF, Ductmate, Durodyne, Radiant T35m, MEZ, Nexus, or Ward flange systems. You now have the option to choose the universal breakaway connection on fire dampers, smoke, and combination fire smoke dampers. You can order your dampers with breakaway connection three different ways:

- Universal flange attached to one end of the sleeve
- Universal flange attached to both ends of the sleeve
- One end attached and one shipped loose

S and Drive connection uses drive slip connection on the side of the hemmed sleeve and S-slip joints are used on top and bottom.

To view the UL 555 Duct Impact Test showing the benefit of a Quick Connect Breakaway Connection, visit our resource video library at greenheck.com.



Greenheck has a wide range of devices to test your combination fire smoke or smoke damper.

GTS-1

- Combination fire smoke damper equipped with TOR
- Toggle switch
- Indicator lights
 - Red for closed damper
 - Green for open damper
- Factory mounted or shipped loose



GTS-1



GTS-2

GTS-2

- Combination fire smoke damper equipped with TOR
- Key switch
- Indicator lights
 - Red for closed damper
 - Green for open damper
- Shipped loose



GTS-3



GTS-4

GTS-3

- Combination fire smoke damper equipped with RRL/OCI or TOR
- Smoke damper with an OCI
- Indicator lights
 - Red for closed damper
 - Green for open damper
- Momentary test switch
- Factory mounted or shipped loose

GTS-4

- Combination fire smoke damper equipped with RRL/OCI or TOR
- Smoke damper with an OCI
- Indicator lights only
 - Red for closed damper
 - Green for open damper
- Factory mounted or shipped loose



Momentary Test Switch

Momentary Test Switch

- Combination fire smoke or smoke damper
- Test and cycle the damper on location
- Factory mounted

Two Position Toggle Switch

- Combination fire smoke or smoke damper
- Open and closes the damper
- Factory mounted



Toggle Switch

Blade Indicators and Smoke Detectors

Blade Indication

Open Close Indicator (OCI) - The OCI option provides two switches, providing positive blade indication. One indicates when the damper is open, and the other indicates when the damper is closed. The switches are physically linked to a damper blade and therefore give true “positive blade indications”.



OCI

Actuator End Switches

Actuator end switches are also commonly referred to as auxiliary switches. These switches are internal to the actuator and perform the same function as the OCI option. These switches are also normally wired to indicator lights (at the Firefighter’s Smoke Control Station), or used for other purposes as required. The end switches are offered as an alternative to the OCI option based on preference of the design engineer.



Low Flow

Smoke Detectors

A smoke detector’s purpose is to sample air passing through a duct and provide an alarm upon detection of smoke. The detectors can be used to control smoke and combination fire smoke dampers.

Low Flow Smoke Detector - This smoke detector is rated for velocities from 100 to 4000 ft/min. (0.5 to 20.3 m/s). These smoke detectors can either be factory mounted and wired or shipped loose.

No Flow Smoke Detector - The no flow smoke detector is rated for systems without a minimum operating velocity. This smoke detector is rated for air velocities from 0 to 3000 ft/min. (0 to 15.2 m/s) and is mounted internally to the damper sleeve. It can be used on dampers with a maximum of two actuators. The no flow smoke detector has a built-in test switch.



No Flow

Security Bars

When a specification requires security bars to be installed with the damper, they can be shipped assembled. Installation of security bars into dampers reduces security risks and reinforces the equipment. Security bars maintain the UL Classification for all products and are welded into the sleeve. Two types of security bars are available:

- Cross bar - round steel bars placed horizontal and vertical on center, based on customer selection or
- Punched mid bar - round steel bars placed vertical on center, based on customer selection, with flat mid bars placed horizontal on dampers higher than 24 inches (610mm).



Security Bars

Transitions and Installation

Transitions

When a rectangular combination fire smoke or smoke damper is being used in conjunction with round or oval ductwork, it must be supplied with round or oval transitions on one or both ends of the sleeve. A Type C transition may be used to increase free area and minimize pressure drop. Dampers should be ordered to the duct dimensions.

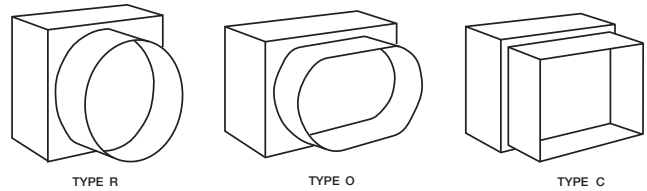

Transitions for Smoke and Combination Fire Smoke Dampers

Clean Wrap

In the Indoor Air Quality section of the Green Building and LEED Core Concepts Guide, you need to protect air quality during construction and prevent dust and particulate buildup. Greenheck offers Clean Wrap to help meet this requirement. Clean Wrap is a thin film that adheres to the ends of the damper sleeve to prevent dust, dirt and debris from entering the damper at the construction site.



Helpful Installation Decals

Greenheck dampers feature decals highlighting damper areas that are important to an accurate installation. Our decals point out critical damper areas and include messages to make installation hassle-free. We are the only damper manufacturer to offer these simple, yet very helpful tips, right on the damper.



Installation Booklets

Greenheck includes installation booklets in every shipment of dampers. These booklets include installation guidelines such as field-supplied sleeves, single side retaining angles, and much more to help with your installation needs.



Convenience Features

Tag Label

Greenheck labels—*on all dampers*—include the tag information for your order (30 character limit). This label provides the damper model, size, actuator model, and purchase order number. This label will help save time in the field when you have multiple locations for dampers on the job site. On combination fire smoke, smoke and fire dampers, you will see a QR code on the label too. When you scan the QR code with your smartphone, you will be directed to www.greenheck.com for model specific information.



One Piece Retaining Angles

Greenheck’s one piece retaining angle, the POC (literally named for being a “Piece of Cake”) makes combination fire smoke damper installation a breeze. The POC simply wraps around the sleeve of the damper, connections are made as described in our installation instructions, and that’s it! Simple! Like their rectangular counterparts, round one-piece retaining plates easily wrap around the sleeve of the damper and tighten with the clamping screw for simplified installation.



Single Side Retaining Angles and Plates

Rectangular dampers and sleeve assemblies are qualified for installations with retaining angles on **one side** of the partition only. Round dampers and sleeve assemblies may be installed with retaining plates on **one side** only. Damper assemblies exceeding these maximum sizes must be secured with retaining angles or plates on **both sides** of the partition.

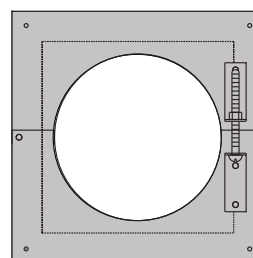

Retaining Plate for Round Dampers

A 3-side retaining angle is qualified in applications where the damper rests directly on the base of the wall opening (example: underfloor application). A retaining angle is not required on the bottom side of the damper.

| Maximum Qualified Damper Size for Single Side and 3-Side* Retaining Angle (Width x Height) | | |
|--|-------------|--------------|
| Mounting | Inches | Millimeters |
| Vertical* | 80 x 50 | 2032 x 1270 |
| | 50 x 80 | 1270 x 2032 |
| | 40 x 100 | 1016 x 2540 |
| Horizontal | 144 x 96 | 3658 x 2438 |
| Round Fire and Fire Smoke | 24 diameter | 610 diameter |

Tight Space Constraints – Use Firestop

Where standard retaining angle installations will not work, Greenheck has a UL approved firestop and retaining clip installation which allows contractors to meet UL requirements where space limits capabilities.

| Firestop and Retaining Clip Installation Maximum Damper Size (Width x Height) | |
|---|-------------|
| Inches | Millimeters |
| 72 x 96 | 1829 x 2438 |



Two Dampers in One - Manual Balancing Fire Damper

This allows them to function as both a fire damper and manual balancing damper. All Greenheck multi-blade fire dampers are supplied with a manual quadrant.



Two Dampers in One - Modulating Fire Smoke or Smoke Dampers

Greenheck offers UL approved modulating actuators on smoke and combination fire smoke dampers. A modulating actuator combines the functions of a control damper and a fire smoke or smoke damper into one unit reducing the number of dampers needed and the overall project cost.



Damper Model Definition

FSD-311V

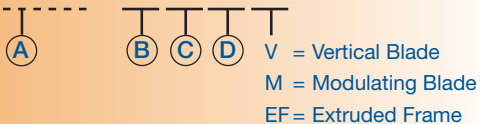

EXAMPLE: Combination Fire-Smoke Damper with Vertical Steel Airfoil Blades
1½ Hour Fire Rating
Class I Leakage

DFD-150X12

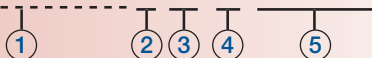

EXAMPLE: Dynamic Fire Damper with 1½ Hour Fire Rating
3-¹¹/₁₆ inch Frame
Low to Medium Pressure
12 inch Integral Sleeve

| | |
|----------|--|
| 1 | Product Type: Curtain |
| DFD | Dynamic Fire Damper |
| FD | Static Fire Damper |
| ODFD | Out-of-Wall Dynamic Fire Damper |
| OFD | Out-of-Wall Static Fire Damper |
| SSDFD | 304 Stainless Steel Dynamic Fire Damper |
| SSFD | 304 Stainless Steel Static Fire Damper |
| 2 | Fire Resistance Rating |
| 1 | 1½ Hour |
| 3 | 3 Hour |
| 3 | Frame Style |
| 0 | Ultrathin - 1½ in. (38mm) |
| 1 | Narrowline - 2 ³ / ₁₆ in. (56mm) |
| 5 | Standard - 3 ¹¹ / ₁₆ in. (94mm) |
| 4 | Pressure Rating |
| 0 | Pressure (up to 4 in. wg) |
| 5 | Damper with Integral Sleeve |
| X12 | 12 in. long |
| X14 | 14 in. long |
| X16 | 16 in. long |

| | |
|----------|---|
| A | Product Type: Multi-Blade and Round |
| CFSD | Corridor Ceiling Combination Fire Smoke Damper |
| DFD | Dynamic Fire Damper |
| DFDAF | Dynamic Fire Damper - Airfoil Blade Damper |
| DFDR | Round Dynamic Fire Damper |
| FDR | Round Static Fire Damper |
| FSD | Combination Fire Smoke Damper |
| FSDR | Round Combination Fire Smoke Damper |
| GFSD | Grille Access Combination Fire Smoke Damper |
| HSD | Heavy Duty Smoke Damper |
| OFSD | Out-of-Wall Combination Fire Smoke Damper |
| SEDFD | 316 Stainless Steel Dynamic Fire Damper |
| SEFSD | 316 Stainless Steel Combination Fire Smoke Damper |
| SEFSDR | Round 316 Stainless Steel Combination Fire Smoke Damper |
| SESMD | 316 Stainless Steel Smoke Damper |
| SESMDR | Round 316 Stainless Steel Smoke Damper |
| SMD | Smoke Damper |
| SMDR | Round Smoke Damper |
| SSDFDR | Round 304 Stainless Steel Dynamic Fire Damper |
| SSFDR | Round 304 Stainless Steel Static Fire Damper |
| SSFSD | 304 Stainless Steel Combination Fire Smoke Damper |
| SSFSDR | Round 304 Stainless Steel Combination Fire Smoke Damper |
| SSSMD | 304 Stainless Steel Smoke Damper |
| SSSMDR | Round 304 Stainless Steel Smoke Damper |
| B | Blade Style |
| 2 | Fabricated Steel with Triple Vee Reinforcements (3V) |
| 3 | Fabricated Steel Airfoil |
| 4 | Extruded Aluminum Airfoil |
| 5 | Round |
| C | Fire Rating |
| 0 | Smoke Damper-No Fire Rating |
| 1 | 1½ Hour |
| 3 | 3 Hour |
| D | Leakage |
| 0 | No Leakage Rating |
| 1 | Leakage Class I |
| 2 | Leakage Class II |
| 3 | Leakage Class III |

Drive Arrangement Definition

The following breakdown of a drive arrangement code is a good reference in understanding what each number and letter signifies.

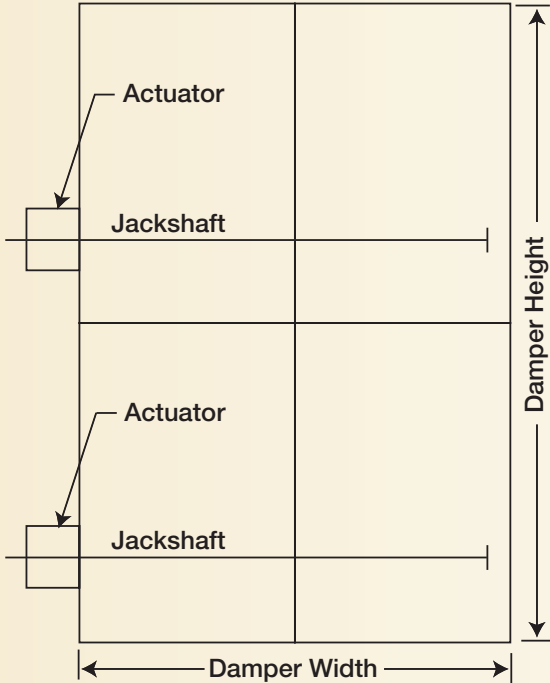

22-2FEL-2

① ② ③ ④ ⑤ ⑥ ⑦

| | |
|---|--|
| 1 | Number of sections wide |
| 2 | Number of sections high |
| 3 | Number of actuators |
| 4 | Who supplies the actuators F = Factory (always) on UL dampers |
| 5 | Actuator mounting E = External I = Internal B = Both internal and external |
| 6 | Actuator location (viewed from jackshaft side) L = Left hand drive R = Right hand drive B = Both right and left |
| 7 | Number of jackshafts |

Listings/Approvals

| UL Category EMME/CABS (all models) | California State Fire Marshal | |
|---------------------------------------|---|----------------|
| EMME R13317 | DFD-2xx; DFDAF-3xx; SSDFD-2xx | 3225-0981:0103 |
| | All DFD/FD curtain style | 3225-0981:0102 |
| | GFSD/FSD/OFSD/SSFSD (fire) | 3225-0981:0103 |
| | GFSD/FSD/OFSD/SSFSD/SMD/SSSMD (leakage) | 3230-0981:0104 |
| | CFSD (leakage) | 3230-0981:0105 |
| | CFSD (fire) | 3225-0981:0106 |
| | DFDR/FDR/FSDR/SSFSDR (fire) | 3225-0981:0112 |
| | FSDR/SSFSDR/SMDR/SSSMDR (leakage) | 3230-0981:0113 |
| EMME R13317 CABS R13446 | CRD-501 | 3230-0981:0113 |
| CABS R13446 | CRD-1/CRD-1xx/CRD-2 | 3225-0981:0101 |
| | CRD-60, -60X | 3226-0981:0111 |
| | CRD-2WT | 3226-0981:0500 |

Specification Checklist

| | Ceiling Radiation Dampers | Combination Fire Smoke Dampers | Fire Dampers | Smoke Dampers |
|--|---------------------------|--------------------------------|--------------|---------------|
| UL Standard | | | | |
| UL 555 | | ✓ | ✓ | |
| UL 555C | ✓ | | | |
| UL 555S | | ✓ | | ✓ |
| NFPA | | | | |
| 80 | | ✓ | ✓ | |
| 90A | ✓ | ✓ | ✓ | |
| 92 | | ✓ | | ✓ |
| 101 | ✓ | ✓ | ✓ | ✓ |
| 105 | | ✓ | | ✓ |
| Fire Resistance | | | | |
| 1½ Hour | ✓ | ✓ | ✓ | |
| 3 Hour | | ✓ | ✓ | |
| Fire Closure Temperature | | | | |
| 165°F (74°C) | ✓ | ✓ | ✓ | |
| 212°F (100°C) | ✓ | ✓ | ✓ | |
| 250°F (121°C) | | ✓ | ✓ | |
| 286°F (141°C) | | | ✓ | |
| 350°F (177°C) | | ✓ | ✓ | |
| Elevated Operational Temperature | | | | |
| 250°F (121°C) | | ✓ | | ✓ |
| 350°F (177°C) | | ✓ | | ✓ |
| Differential Pressure <i>(applies to dynamic rated fire dampers, combination fire smoke dampers, smoke dampers)</i> | | | | |
| 4 in. wg (1 kPa) | | ✓ | ✓ | ✓ |
| 6 in. wg (1.5 kPa) | | ✓ | ✓ | ✓ |
| 8 in. wg (2 kPa) | | ✓ | ✓ | ✓ |
| 10 in. wg (2.5 kPa) | | | ✓ | |
| Velocity | | | | |
| 2000 ft/min. (10 m/s) | | ✓ | ✓ | ✓ |
| 3000 ft/min. (15 m/s) | | ✓ | ✓ | ✓ |
| 4000 ft/min. (20 m/s) | | ✓ | ✓ | ✓ |
| Leakage | | | | |
| Class I | | ✓ | | ✓ |
| Class II | | ✓ | | ✓ |
| Class III | | ✓ | | ✓ |
| Mounting | | | | |
| Horizontal | ✓ | ✓ | ✓ | ✓ |
| Vertical | | ✓ | ✓ | ✓ |
| Factory Mounted Actuators | | ✓ | | ✓ |

Please visit our website at www.greenheck.com/products/air-control/dampers for complete specifications.

Modifications to Life Safety Dampers

Field Modifications

The UL mark applies to the product as it is originally manufactured when shipped from the factory. UL does not know what effect a modification may have on the safety of the product or the continued validity of the UL certification mark unless the field modifications have been specifically investigated by UL. Unless UL investigates a modified product, UL cannot indicate that the product continues to meet UL's safety requirements.

Design Modifications

Careful considerations need to be given to alterations or modifications of the fire resistance assemblies. When field issues arise, it is recommended the first contact for assistance be the technical staff provided by the product manufacturer noted for the design. Users of fire resistance assemblies are advised to consult the general Guide Information for each product category and each group of assemblies. The Guide Information includes specifics concerning alternate materials and alternate methods of construction.

Contacting UL

UL provides assistance to the users of fire resistance assemblies and products, which includes clarification of the published information.

UL also provides a service to investigate modifications to the fire resistance assemblies when requested by the design submitter. Requests for clarification should describe the change and include drawings, if necessary.

Requests for clarifications or investigations can be made by contacting UL at:

- Phone 1-877-ULHELPS (1-877-854-3577) ext. 49590
- Email: archservices@ul.com or
- Website: www.ul.com.

Steps to Take When an Unapproved Installation Must be Provided

1. Identify the problem and be ready to explain why an approved installation cannot be made.
2. Research the alternate installation methods that may be applicable and select a practical alternative that provides relative equivalency based on engineering principles.
3. Illustrate your proposed alternative and discuss it with the damper manufacturer (or representative), job design engineer, or both. Obtain an agreement that it is an acceptable alternative.
4. Submit your alternative damper installation to the authority having jurisdiction and obtain formal approval. Only the authority having jurisdiction can approve an alternative combination fire smoke damper installation. It is usually much easier to obtain approval before a damper has been installed. After an installation has been rejected by the inspector, it is often quite difficult to obtain approval.

Most Commonly Asked Questions

Q. Are pneumatic actuators available on smoke and combination fire smoke dampers?

- A. Smoke and combination fire smoke dampers are available with pneumatic or electric actuators (internal or external mount).

Reference: Actuator Selection, page 27

Q. Does the smoke and combination fire smoke damper actuator have to be factory mounted by the damper manufacturer?

- A. Yes. The 7th Edition of UL 555 and 4th Edition of UL 555S require all actuators on smoke and combination fire smoke dampers to be factory mounted.

Reference: Smoke Dampers Installation, page 24

Q. Are there any specific sleeve gauge requirements for combination fire smoke damper installation?

- A. Sleeve gauge or thickness requirements depend on damper size and the type of duct-to-sleeve connections used.

Reference: Sleeve Requirements, page 10

Q. How much space outside the damper sleeve is required to accommodate the actuator installation? Can the actuators be installed inside the sleeve to eliminate external space requirements?

- A. Clearance requirements for externally mounted actuators vary with actuator type. Enough space should be provided to allow for connection of wiring or piping and the replacement of the actuator and/or control components. If clearance is potentially a problem, the damper manufacturer should be contacted for specific clearance requirements. Installing the actuators internally should be considered only as a last resort, as it creates wiring/piping and service difficulties.

Q. How should combination fire smoke dampers be installed?

- A. Combination fire smoke dampers must always be installed in accordance with the manufacturer's installation instructions.

References: Fire Dampers Installation, page 9 through 12
Smoke Dampers Installation, page 24
Combination Fire Smoke Dampers Installation, page 32 through 33

Q. Is there any fire, smoke or combination fire smoke dampers that can be used in corrosive environment applications?

- A. Greenheck has Severe Environment dampers that are constructed out of 316 stainless steel for this application.

Reference: Damper Model Definition, page 56

Q. When do I use a ceiling radiation damper versus a fire damper?

- A. Both dampers are intended to protect openings in horizontal fire barriers. A fire damper is required in a fire rated wall, floor or ceiling or partition when it is penetrated by air ducts or other air transfer openings. A ceiling radiation damper, according to the 2015 IBC (International Building Code), should be used in the following situations:

1. A ceiling radiation damper installed where a duct penetrates the ceiling of a fire resistance rated floor/ceiling or roof/ceiling assembly.
2. A ceiling radiation damper installed at the ceiling line where a diffuser with no duct attached penetrates the ceiling of a fire resistance rated floor/ceiling or roof/ceiling assembly.

Reference: Ceiling Radiation Dampers, page 42 through 44

Inspection, Maintenance and Testing

Inspection and Testing

Once a building is commissioned, the dampers are required to be inspected and tested one year after installation. After one year, the dampers are inspected and tested every 4 years, except in a building containing a hospital, the frequency is every six years per NFPA 80 and NFPA 105.

Dampers are part of the smoke control system and are required to be tested along with the system. Per NFPA 92, the smoke control system is inspected and tested:

- At least semi-annually if it's a dedicated system
- At least annually if it's a non-dedicated system

The damper actuator shall be inspected and cycled per the manufacturer's recommendations.

Maintenance

Dampers do not typically require maintenance as long as they are kept dry and clean. If cleaning is necessary, use mild detergents or solvents. If lubrication is desired for components such as axle bearings, jackshaft bearings, and jamb seals, do not use oil-based lubricants or any other lubricants that attracts contaminants such as dust.

If the damper and/or the actuator are not operable, repairs shall begin as soon as possible.



Models by Manufacturing Location

| Fire Dampers | | |
|-----------------|---------------------------|----------------------------|
| | Manufacturing Location | |
| | Greenheck Fan Corporation | Greenheck India Pvt., Ltd. |
| DFD-110 | ✓ | |
| DFD-150 | ✓ | ✓ |
| SSDFD-150 | ✓ | |
| DFD-150X series | ✓ | ✓ |
| ODFD-150 | ✓ | |
| DFD-210 | ✓ | ✓ |
| DFDAF-300 | ✓ | |
| DFDAF-310 | ✓ | ✓ |
| DFDAF-330 | ✓ | ✓ |
| SEDFD-210 | ✓ | |
| SSDFD-210 | ✓ | |
| DFD-310 | ✓ | |
| DFD-350 | ✓ | ✓ |
| SSDFD-350 | ✓ | |
| FD-100 | ✓ | |
| FD-110 | ✓ | |
| FD-150 | ✓ | ✓ |
| SSFD-150 | ✓ | |
| FD-150X series | ✓ | ✓ |
| OFD-150 | ✓ | |
| FD-300 | ✓ | |
| FD-310 | ✓ | |
| FD-350 | ✓ | |
| SSFD-350 | ✓ | |

| Round UL Dampers | | |
|------------------|---------------------------|----------------------------|
| | Manufacturing Location | |
| | Greenheck Fan Corporation | Greenheck India Pvt., Ltd. |
| DFDR-510 | ✓ | |
| FDR-510 | ✓ | |
| FSDR-511 | ✓ | |
| FSDR-512 | ✓ | |
| SEFSDR-511 | ✓ | |
| SESMDR-501 | ✓ | |
| SMDR-501 | ✓ | |
| SMDR-502 | ✓ | |
| SSDFDR-510 | ✓ | |
| SSFDR-510 | ✓ | |
| SSFSDR-511 | ✓ | |
| SSFSDR-512 | ✓ | |
| SSSMR-501 | ✓ | |

| Combination Fire Smoke & Smoke Dampers | | |
|--|---------------------------|----------------------------|
| | Manufacturing Location | |
| | Greenheck Fan Corporation | Greenheck India Pvt., Ltd. |
| CFSD-211 | ✓ | |
| CFSD-212 | ✓ | |
| FSD-211 | ✓ | ✓ |
| FSD-211M | ✓ | |
| FSD-212 | ✓ | ✓ |
| FSD-213 | ✓ | |
| SEFSD-211 | ✓ | |
| SSFSD-211 | ✓ | |
| FSD-311 | ✓ | ✓ |
| FSD-312 | ✓ | ✓ |
| FSD-311M | ✓ | |
| FSD-312M | ✓ | |
| FSD-311V | ✓ | |
| FSD-331 | ✓ | ✓ |
| GFSD-211 | ✓ | |
| GFSD-212 | ✓ | |
| OFSD-211 | ✓ | |
| OFSD-212 | ✓ | |
| OFSD-311 | ✓ | |
| OFSD-312 | ✓ | |
| SMD-201 | ✓ | ✓ |
| SMD-201M | ✓ | |
| SMD-202 | ✓ | ✓ |
| SMD-203 | ✓ | |
| SSSMD-201 | ✓ | |
| SESMD-201 | ✓ | |
| SMD-301 | ✓ | ✓ |
| SMD-301M | ✓ | |
| SMD-301V | ✓ | |
| SMD-302 | ✓ | ✓ |
| SMD-302M | ✓ | |
| SMD-401 | ✓ | |
| SMD-401M | ✓ | |
| SMD-401EF | ✓ | |
| HSD-401 | ✓ | |

NOTE: Accessories and options vary by manufacturing location. Refer to CAPS to determine what is available.

Greenheck Fan Corporation
P.O. Box 410
Schofield, WI 54476
U.S.A.
Tel. (715) 359-6171
www.greenheck.com

Greenheck India Pvt., Ltd.
541/542, 5th Floor, Tower B3
Spaze I-Tech Park, Sector-49
Sohna Road, Gurgaon, India
+91-124-4272494
www.greenheck.co.in

**We don't "value engineer" -
we engineer value.**



Enjoy Greenheck's extraordinary service, before, during and after the sale.

Greenheck offers added value to our wide selection of top performing, energy-efficient products by providing several unique Greenheck service programs.



- Greenheck's free Computer Aided Product Selection program (CAPS), rated by many as the best in the industry. CAPS helps you conveniently and efficiently select the right products for the challenge at hand.



- Greenheck has been Green for a long time! Our energy-saving products and ongoing corporate commitment to sustainability can help you qualify for LEED credits.

Find out more about these special Greenheck services at greenheck.com or greenheck.co.in.



Building Value in Air

Greenheck delivers value to mechanical engineers by helping them solve virtually any air quality challenges their clients face with a comprehensive selection of

top quality, innovative air-related equipment. We offer extra value to contractors by providing easy-to-install, competitively priced, reliable products that arrive on time.

And building owners and occupants value the energy efficiency, low maintenance and quiet dependable operation they experience long after the construction project ends.



Our Commitment

As a result of our commitment to continuous improvement, Greenheck reserves the right to change specifications without notice.

Specific Greenheck product warranties are located on greenheck.com within the product area tabs and in the Library under Warranties.



Prepared to Support
Green Building Efforts

